

FIG 101

CYLINDER HEAD

T233/T273

P1

Year / Month

2007 / 11

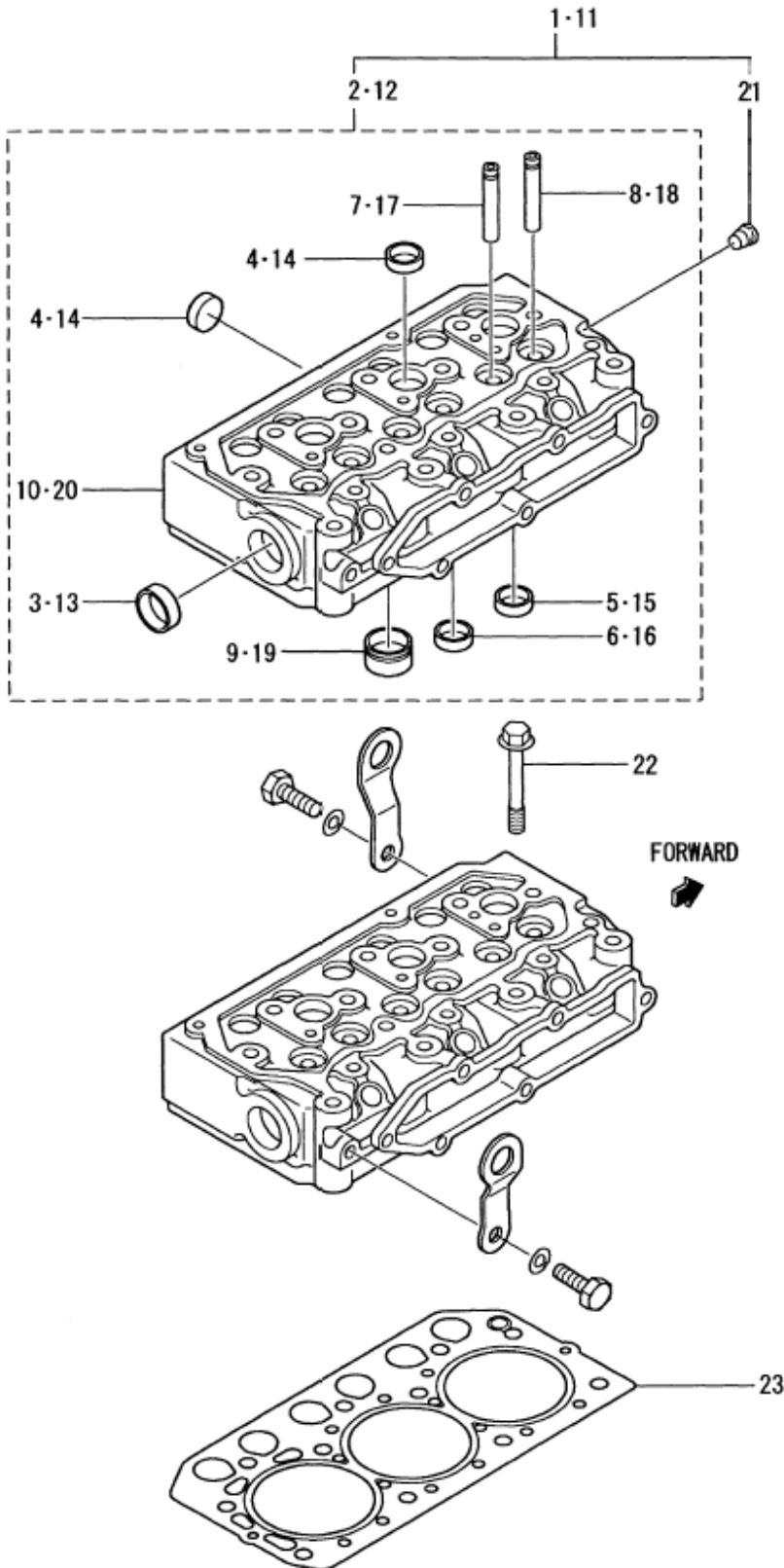
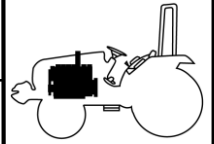

NOTE

T273:S3L2 , T233:S3L

FIG 102

T233/T273

LIFTING EYE

P1

Year / Month

2007 / 11

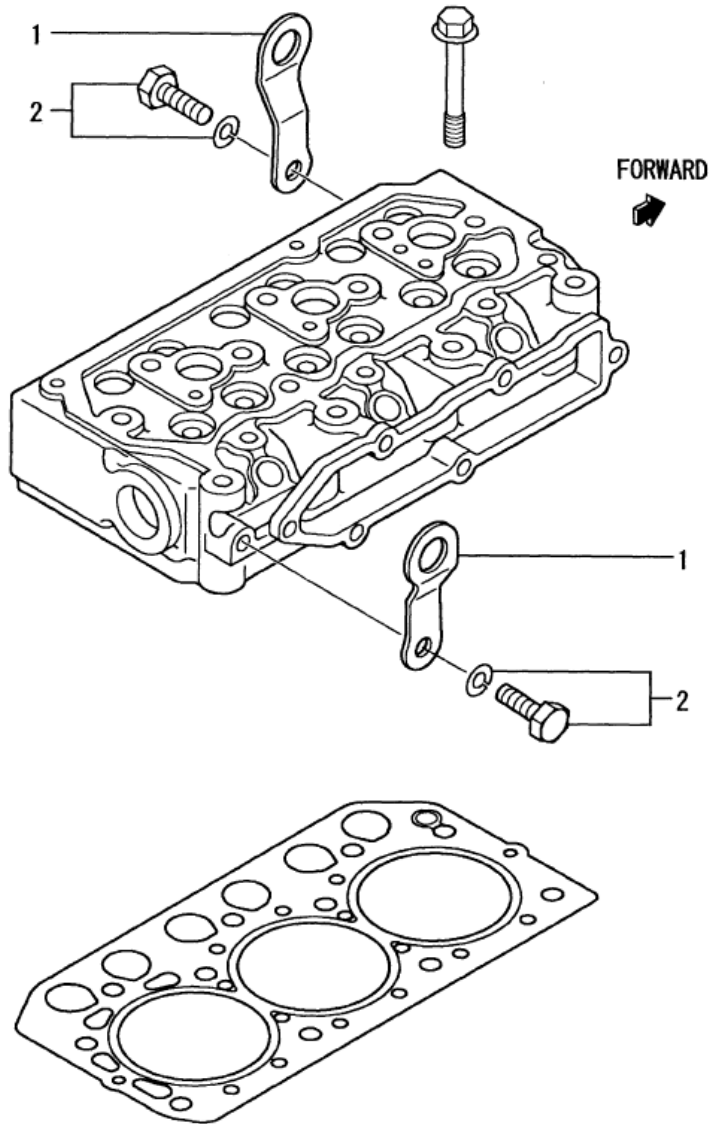
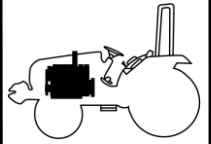

NOTE

T273:S3L2 , T233:S3L

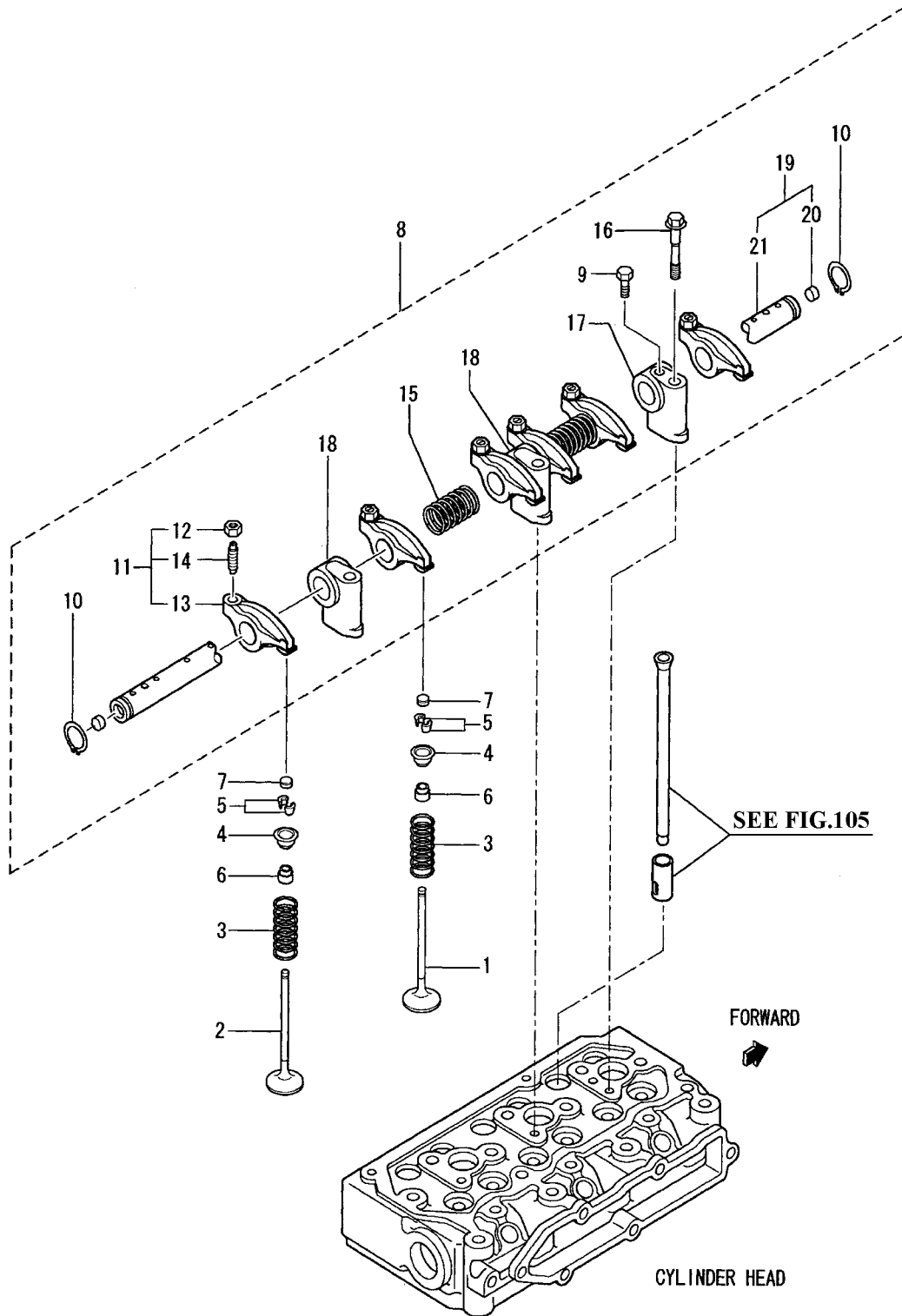
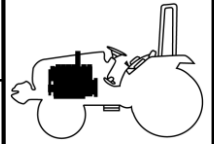

REF. NO. 5 IS AVAILABELE IN A SET WITH PAIR.

NOTE

T273:S3L2 , T233:S3L

FIG 104

ROCKER COVER

P1

Year / Month

2007 / 11

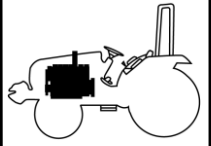

T233/T273

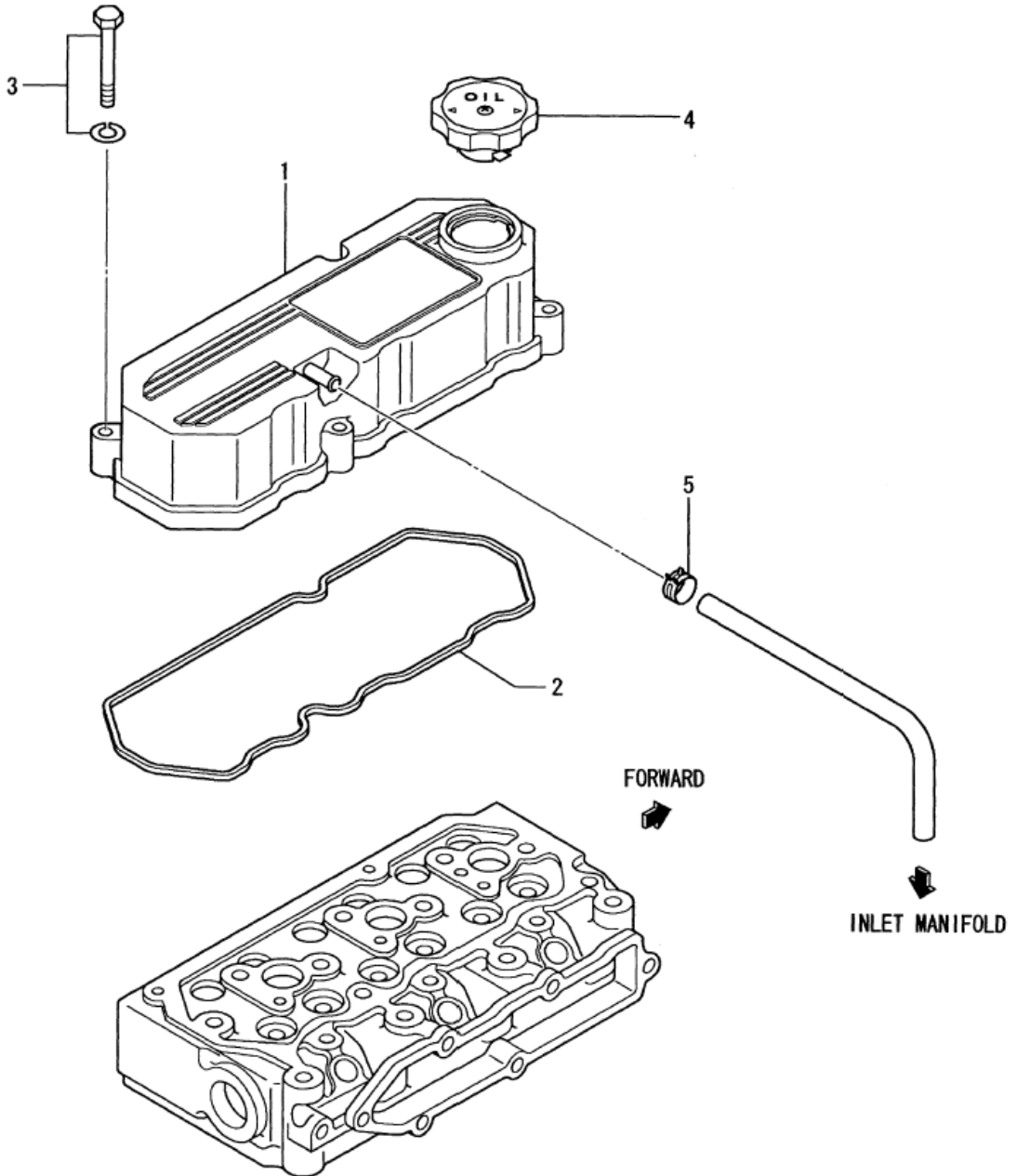

NOTE

T273:S3L2 , T233:S3L

FIG 105

CAMSHAFT & TAPPET

P1

Year / Month

2007 / 11

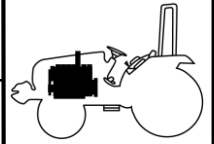

T233/T273

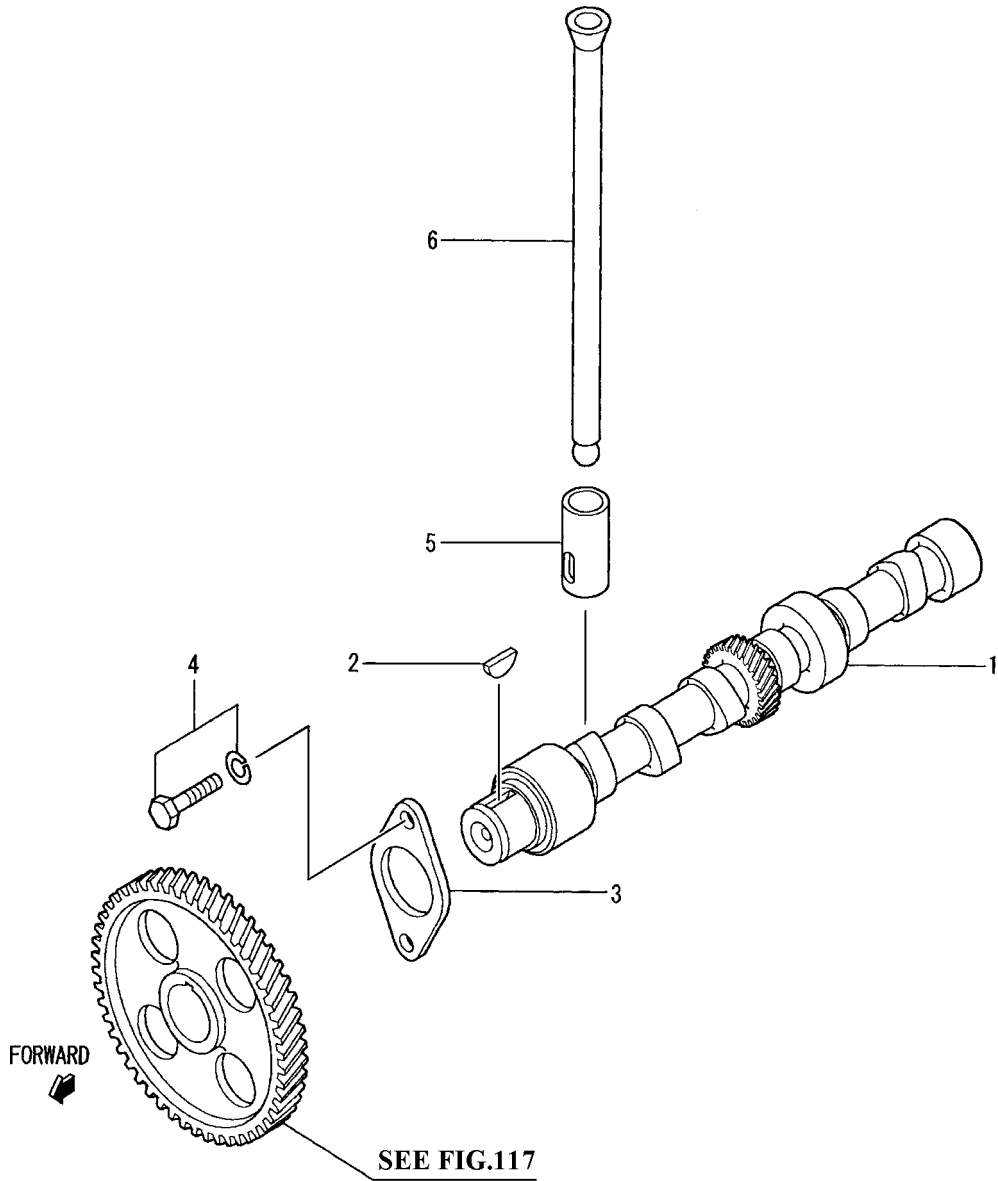

NOTE

T273:S3L2 , T233:S3L

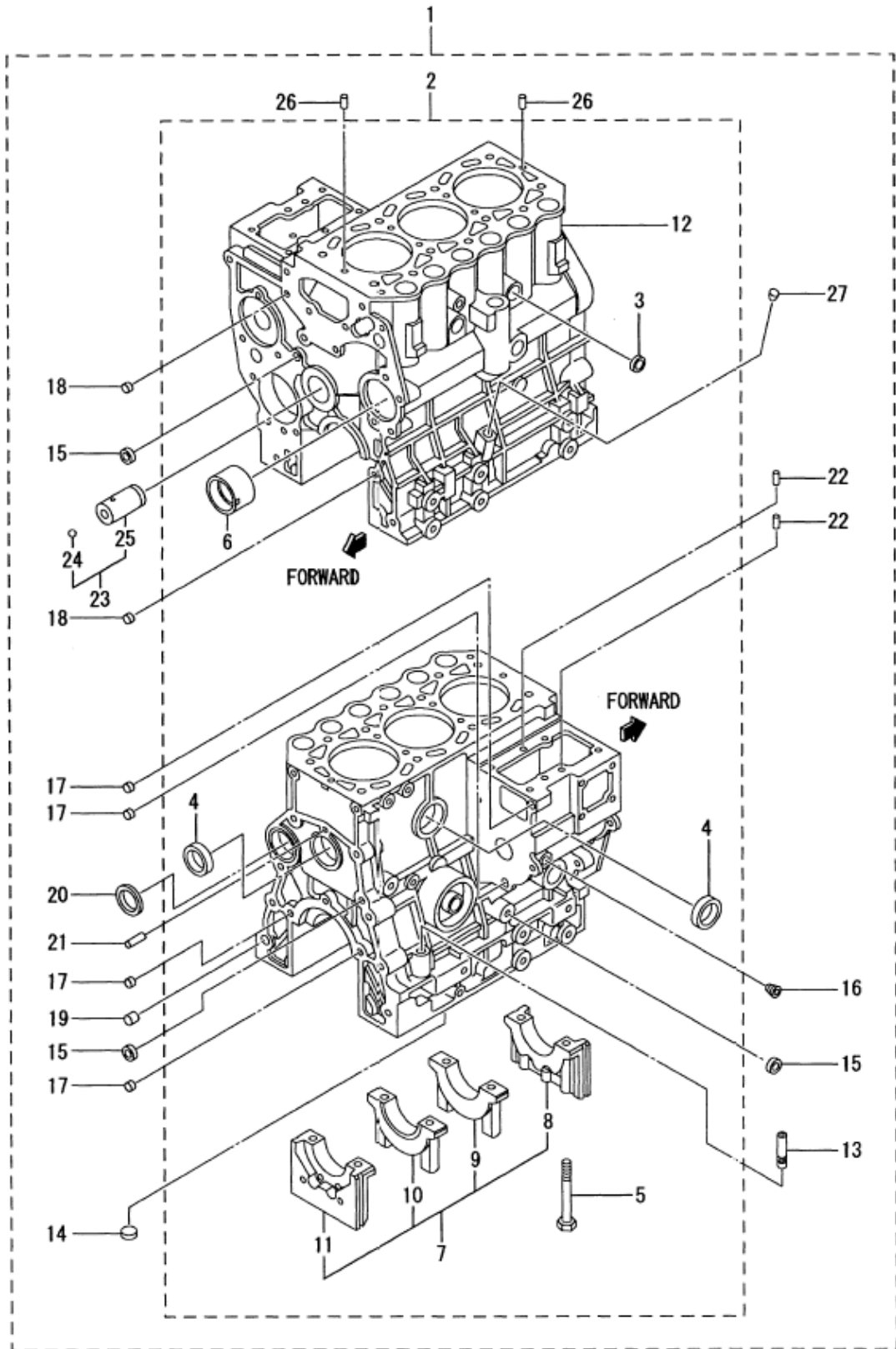
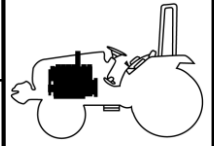

NOTE

T273:S3L2 , T233:S3L

FIG 107

CRANKCASE

P1

Year / Month

2007 / 11

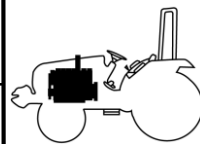

T233/T273

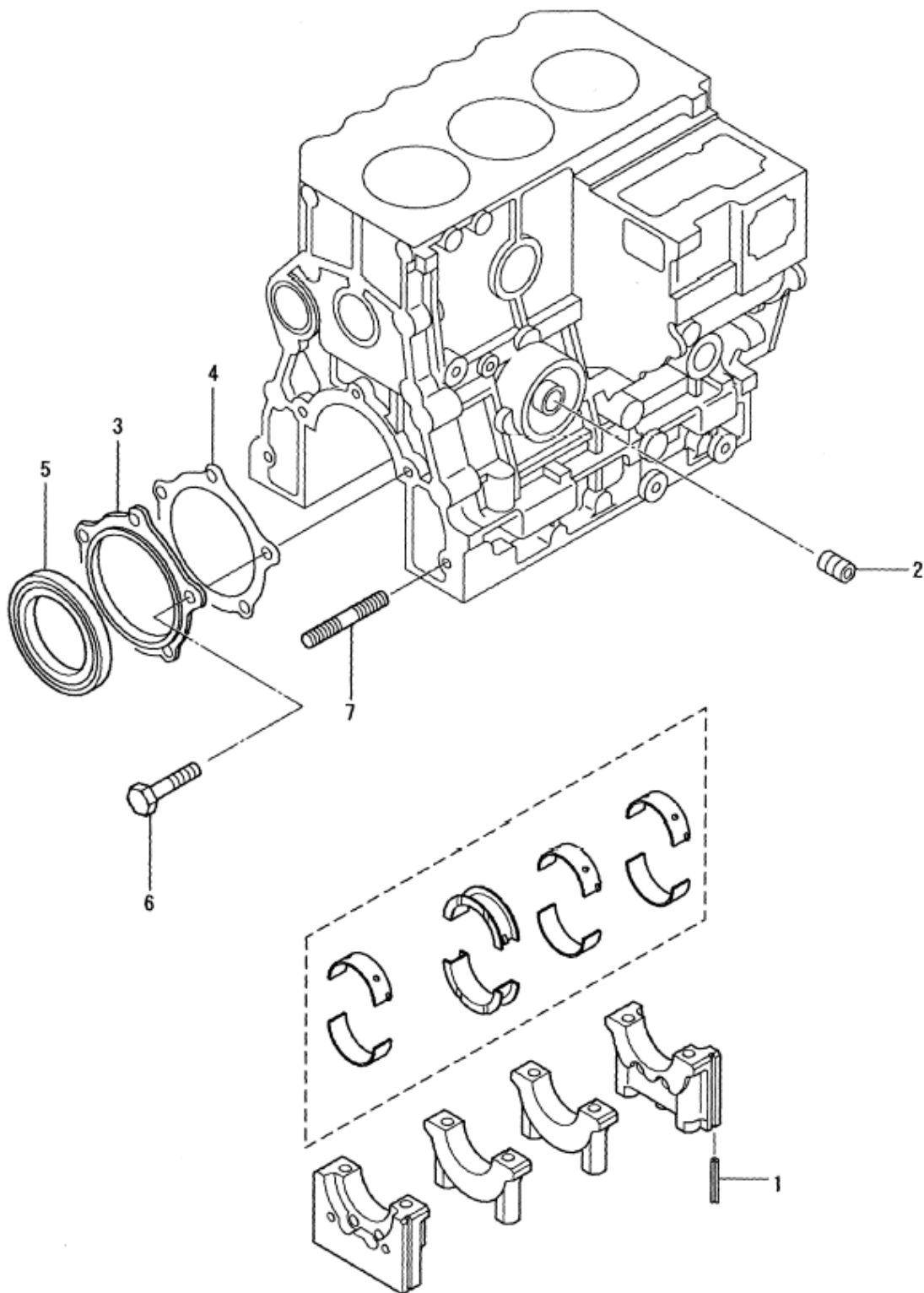

NOTE

T273:S3L2 , T233:S3L

FIG 108

DRAIN COCK & PIPE

P1

Year / Month

2007 / 11

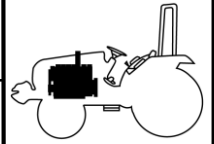

T233/T273

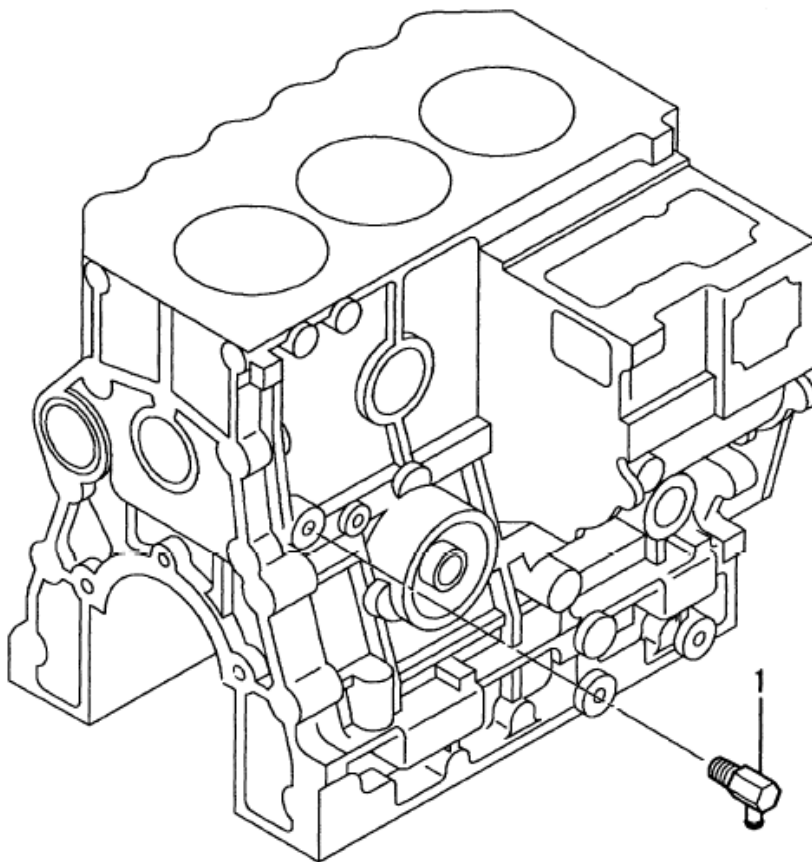

NOTE

T273:S3L2 , T233:S3L



FIG 109

T233/T273

# MAIN BEARING

P1

Year / Month

2007 / 11

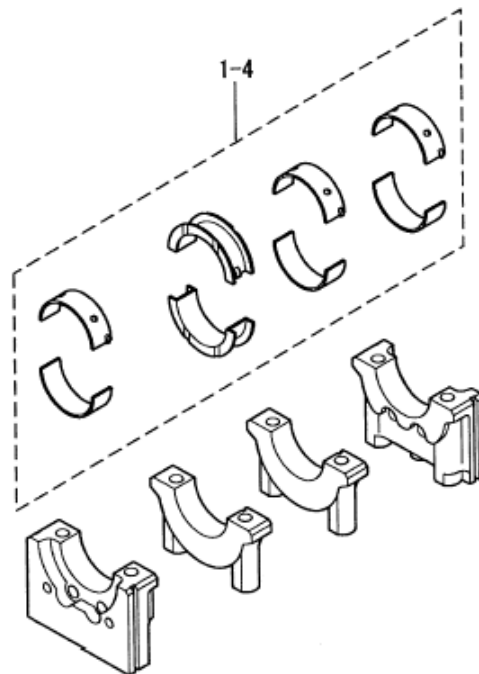
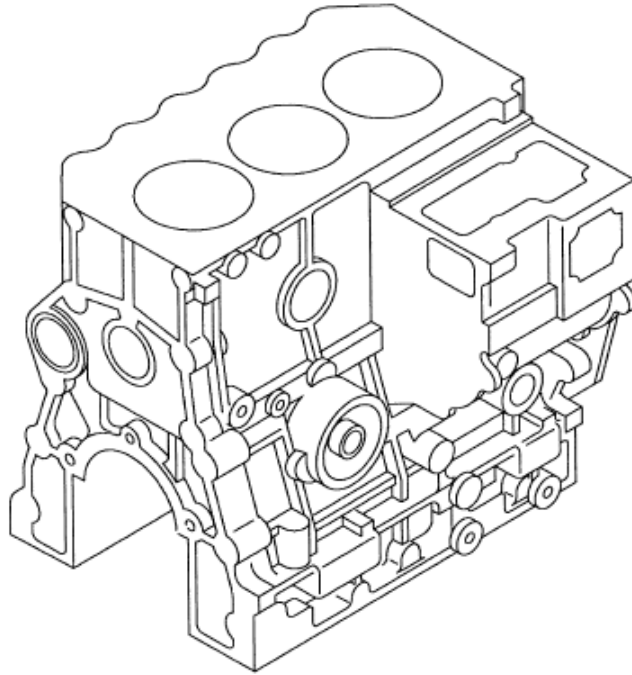
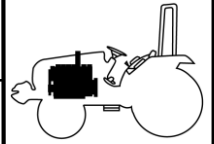

NOTE

T273:S3L2 , T233:S3L

FIG 110

TIMING GEAR CASE

T233/T273

P1

Year / Month

2007 / 11

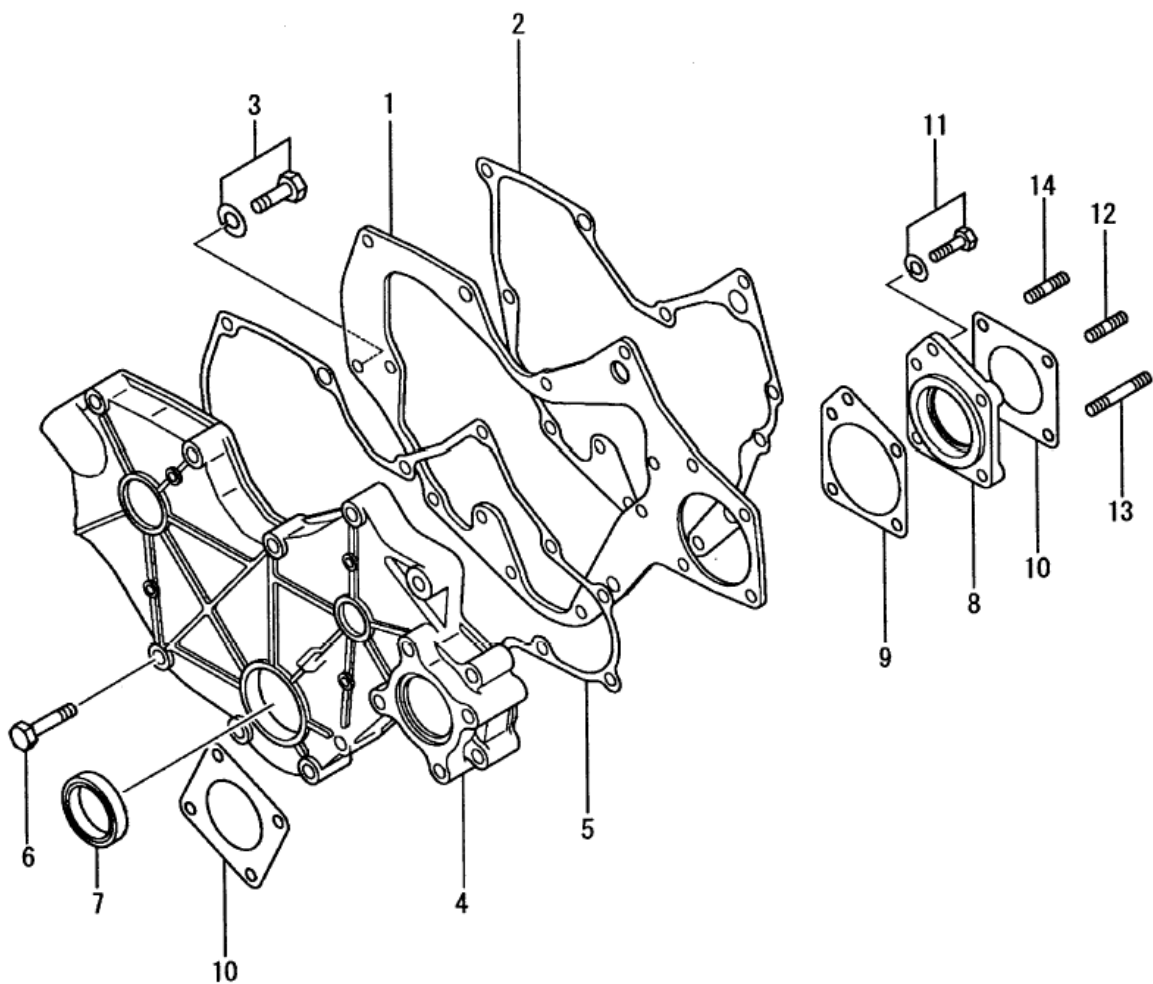
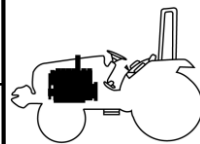

NOTE

T273:S3L2 , T233:S3L

FIG 111

T233/T273

# FLYWHEEL HOUSING

P1

Year / Month

2007 / 11

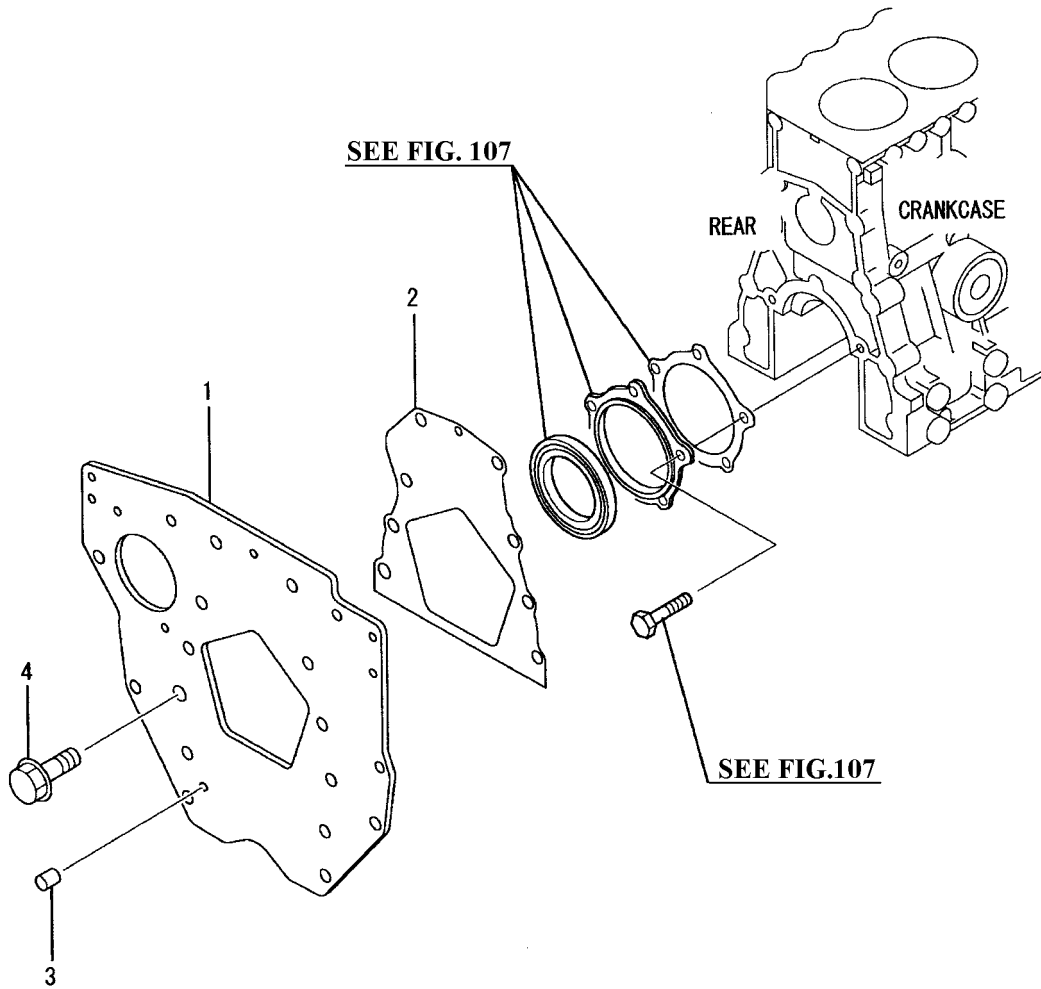
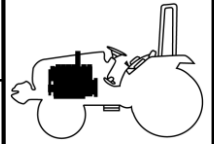

NOTE

T273:S3L2 , T233:S3L

FIG 112

OIL PAN

T233/T273

P1

Year / Month

2007 / 11

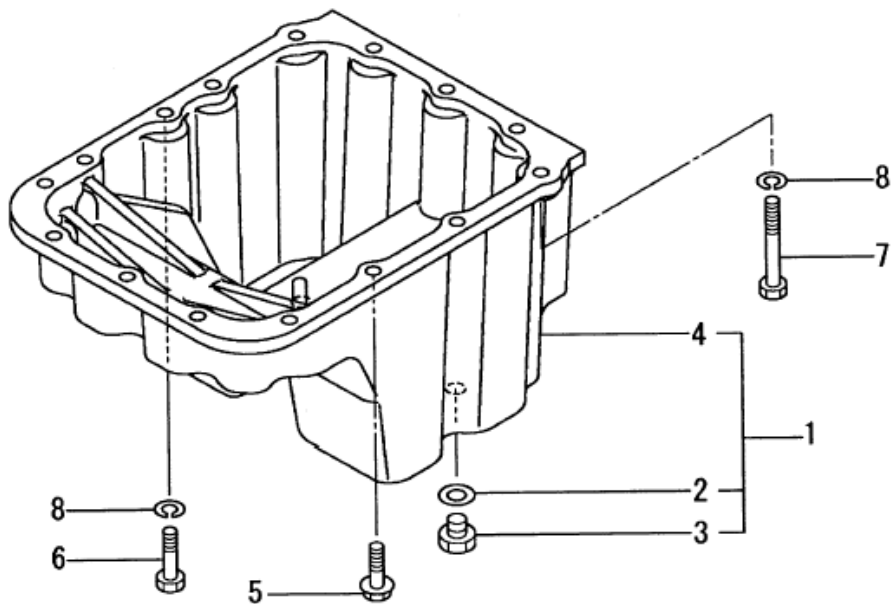
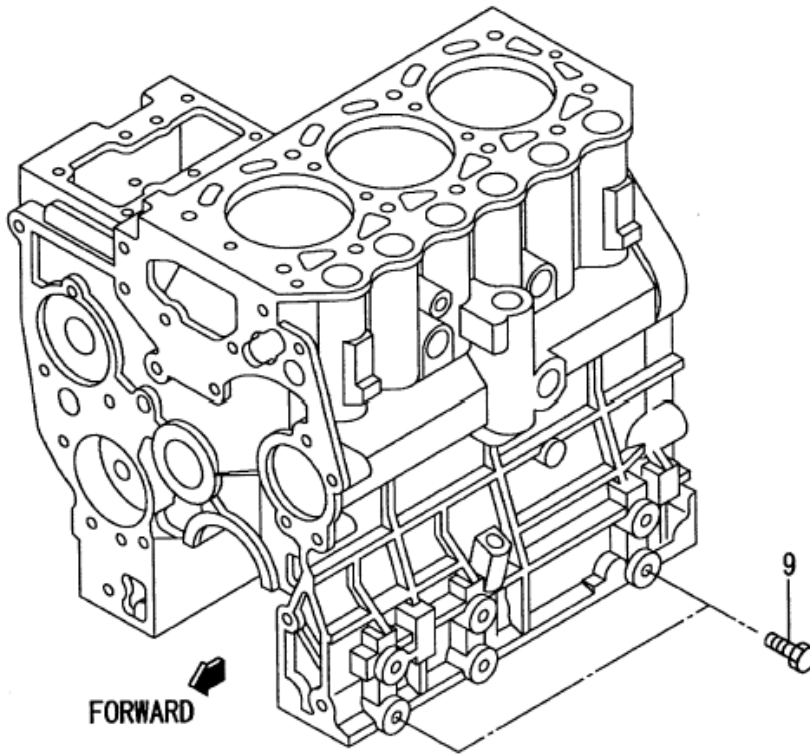
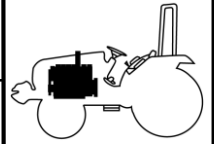

NOTE

T273:S3L2 , T233:S3L

FIG 113

T233/T273

PISTON

P1

Year / Month

2007 / 11

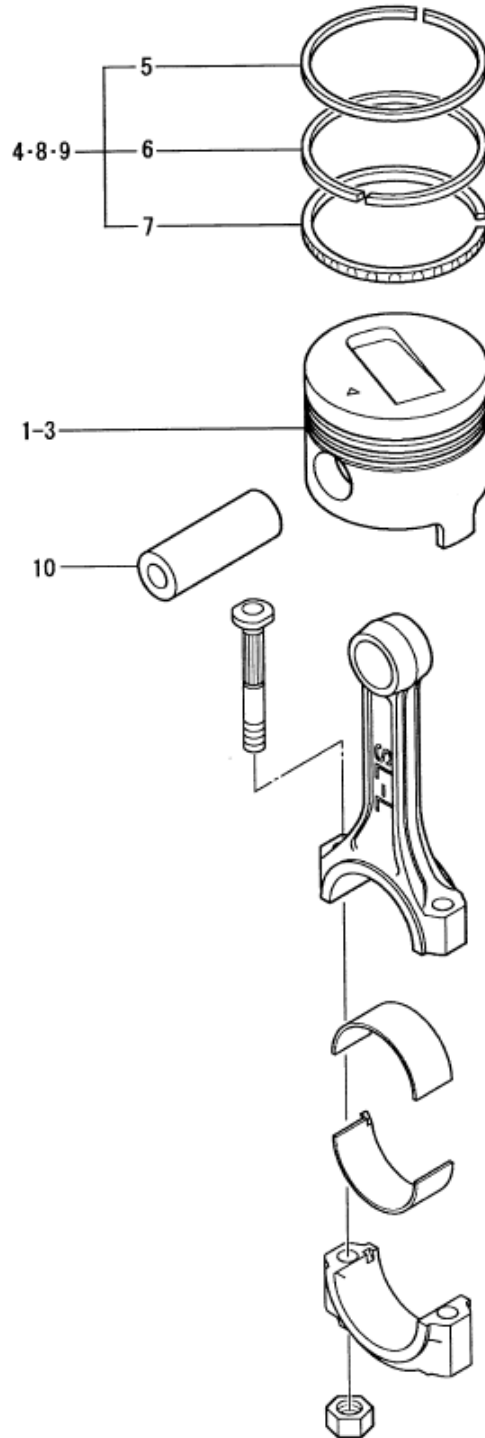
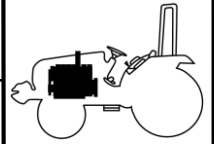

NOTE

T273:S3L2 , T233:S3L

FIG 114

CONNECTING-ROD

P1

Year / Month

2007 / 11

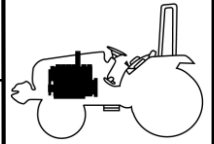

T233/T273

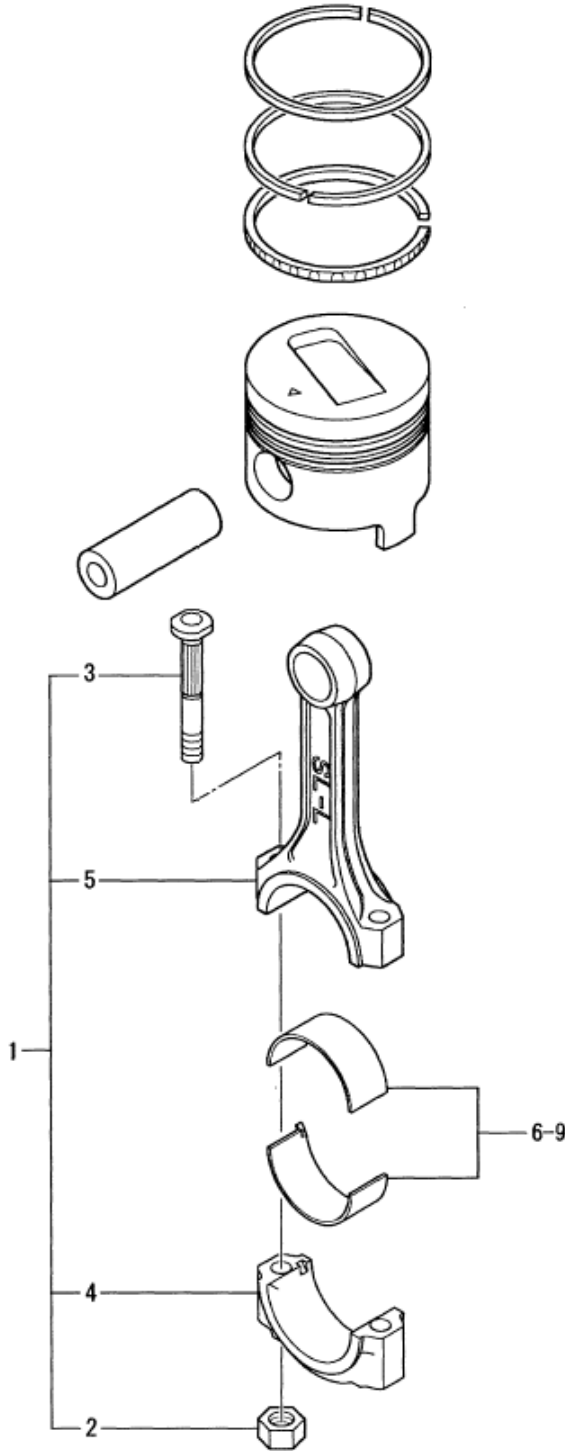

NOTE

T273:S3L2 , T233:S3L

FIG 115

CRANKSHAFT & PULLEY

P1

Year / Month

2007 / 11

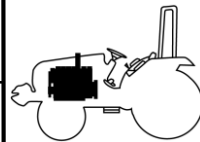

T233/T273

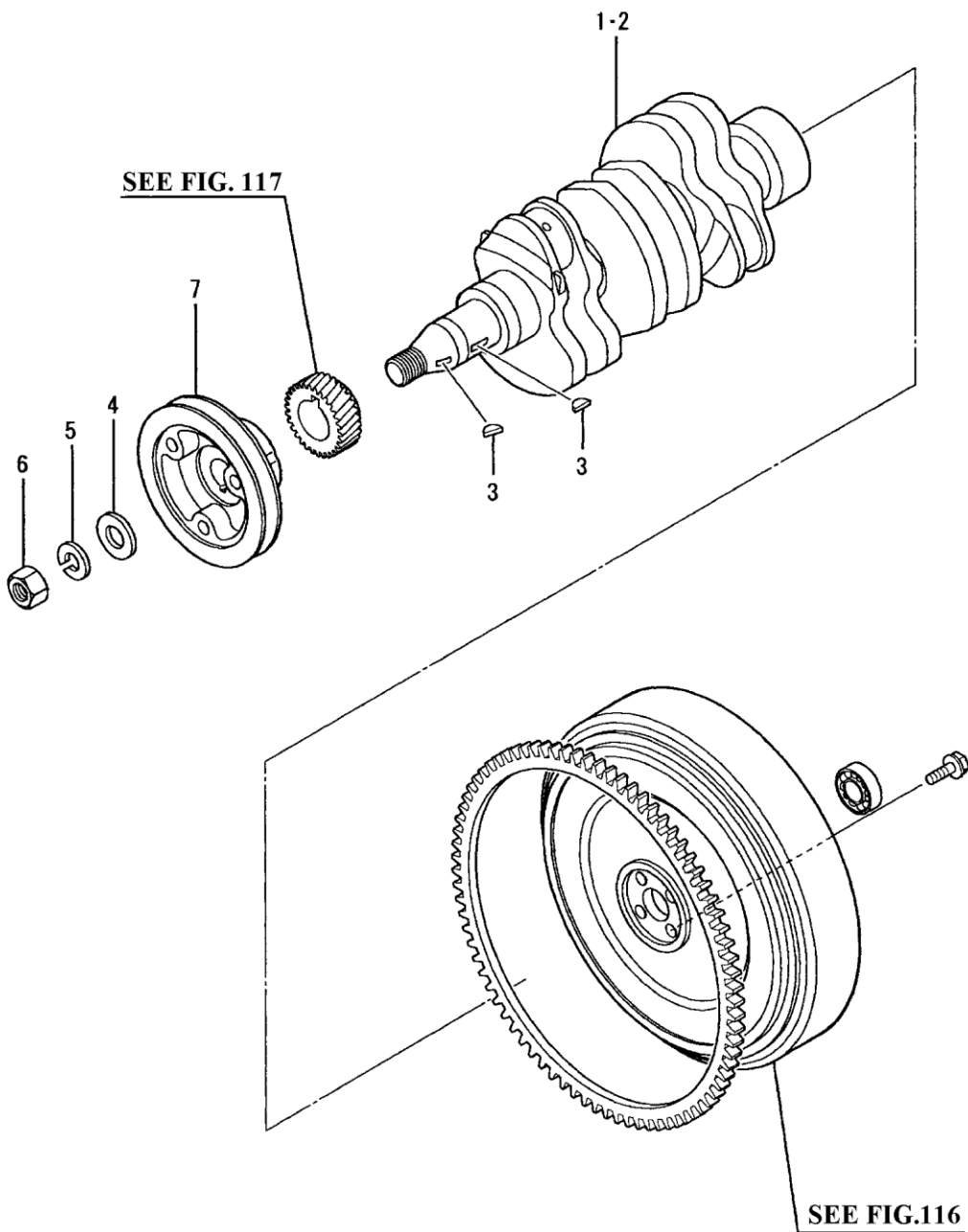

NOTE

T273:S3L2 , T233:S3L

FIG 116

FLYWHEEL

P1

Year / Month

2007 / 11

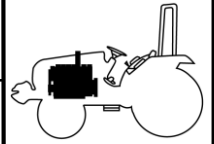

T233/T273

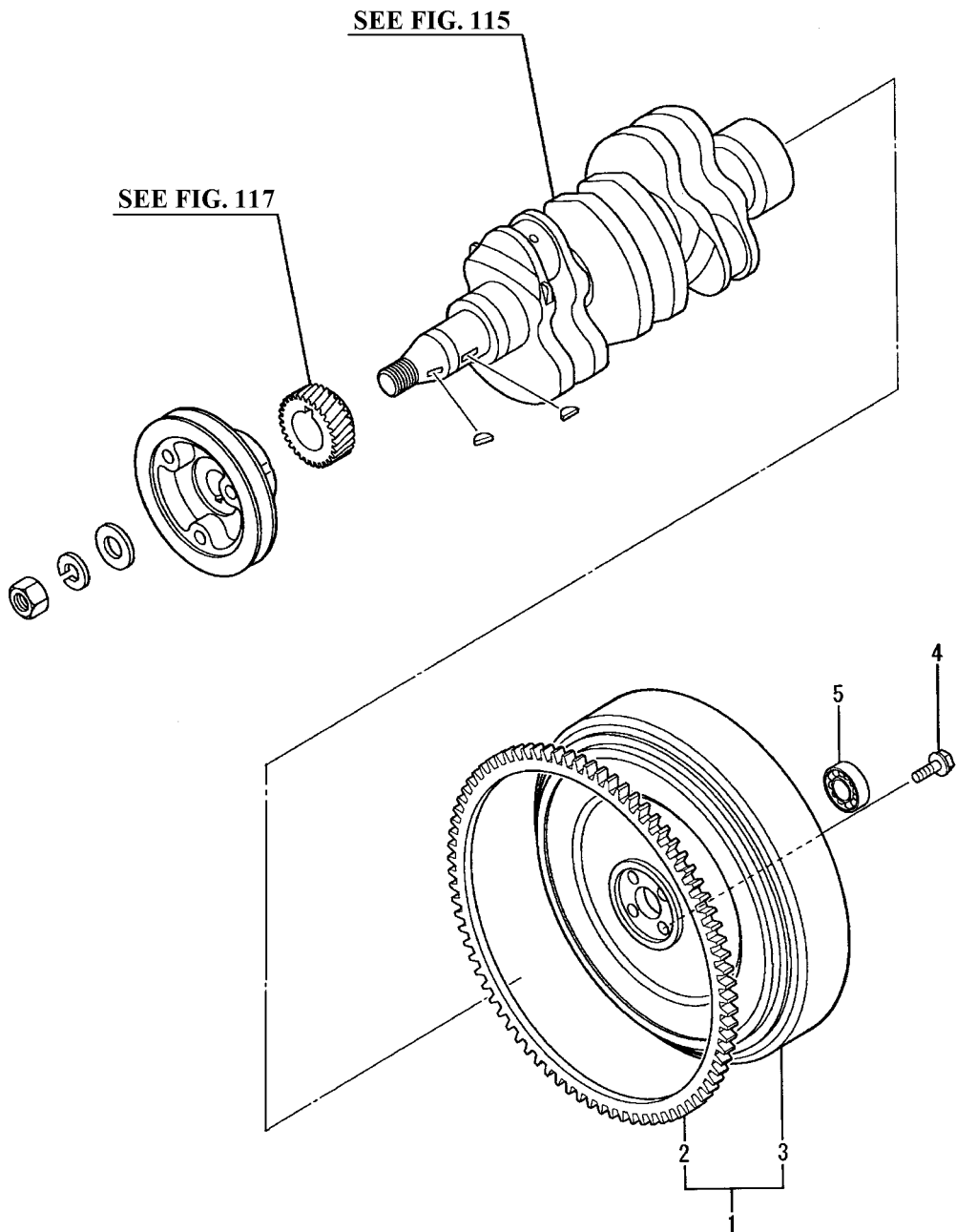

NOTE

T273:S3L2 , T233:S3L



FIG 117

# TIMING GEAR

P1

Year / Month

2007 / 11

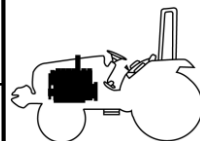

T233/T273

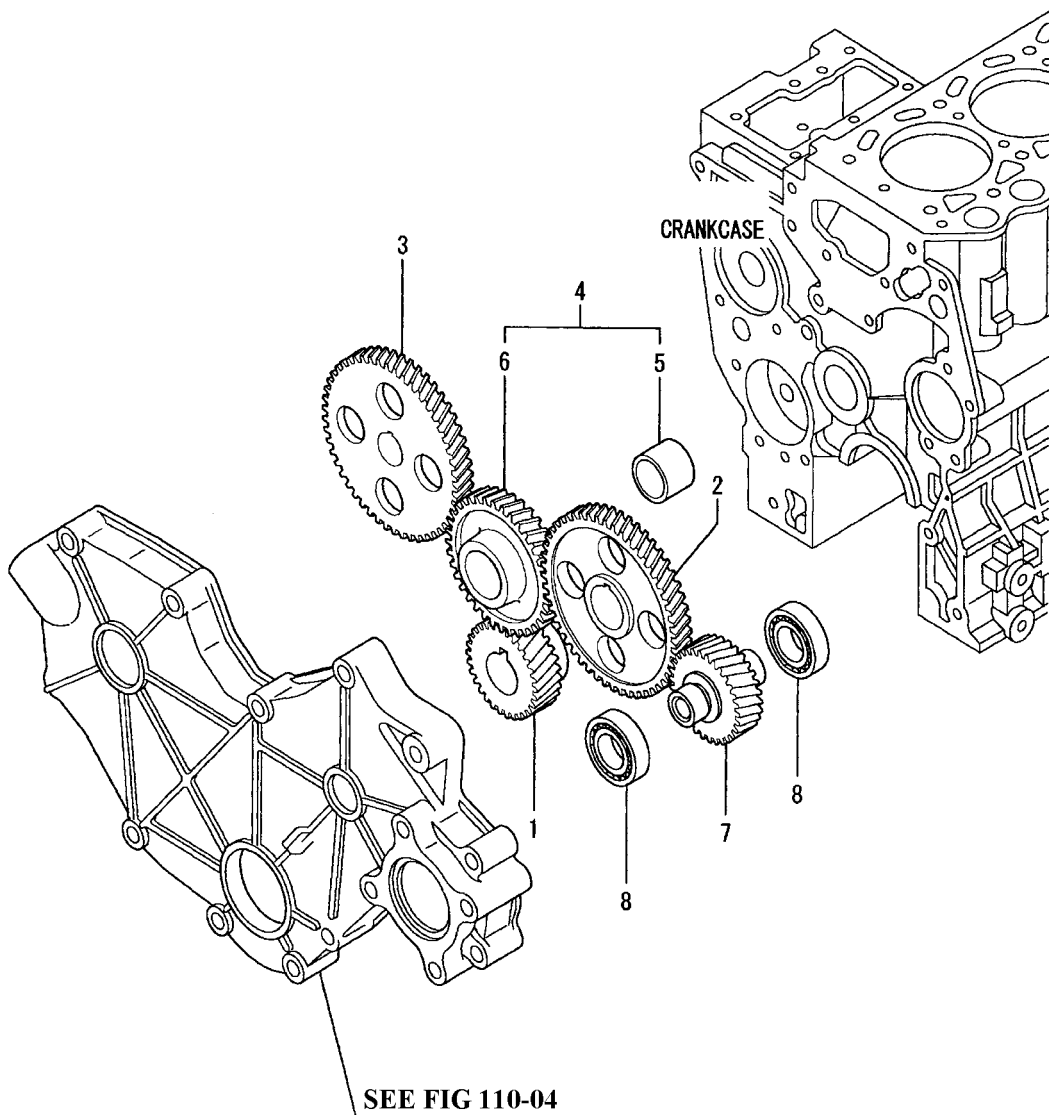

NOTE

T273:S3L2 , T233:S3L

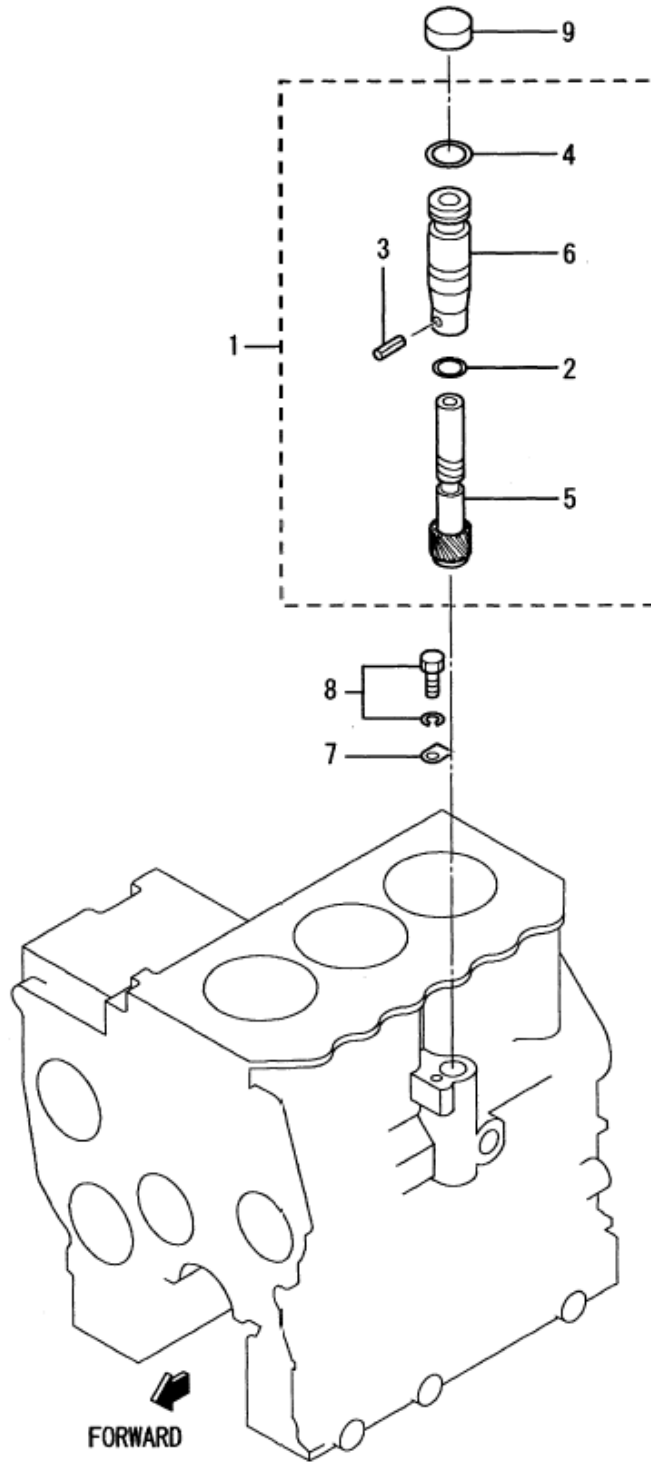
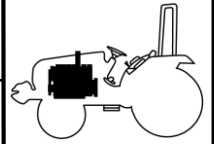

NOTE T273:S3L2 , T233:S3L

FIG 119

T233/T273

# INLET SYSTEM

P1

Year / Month

2007 / 11

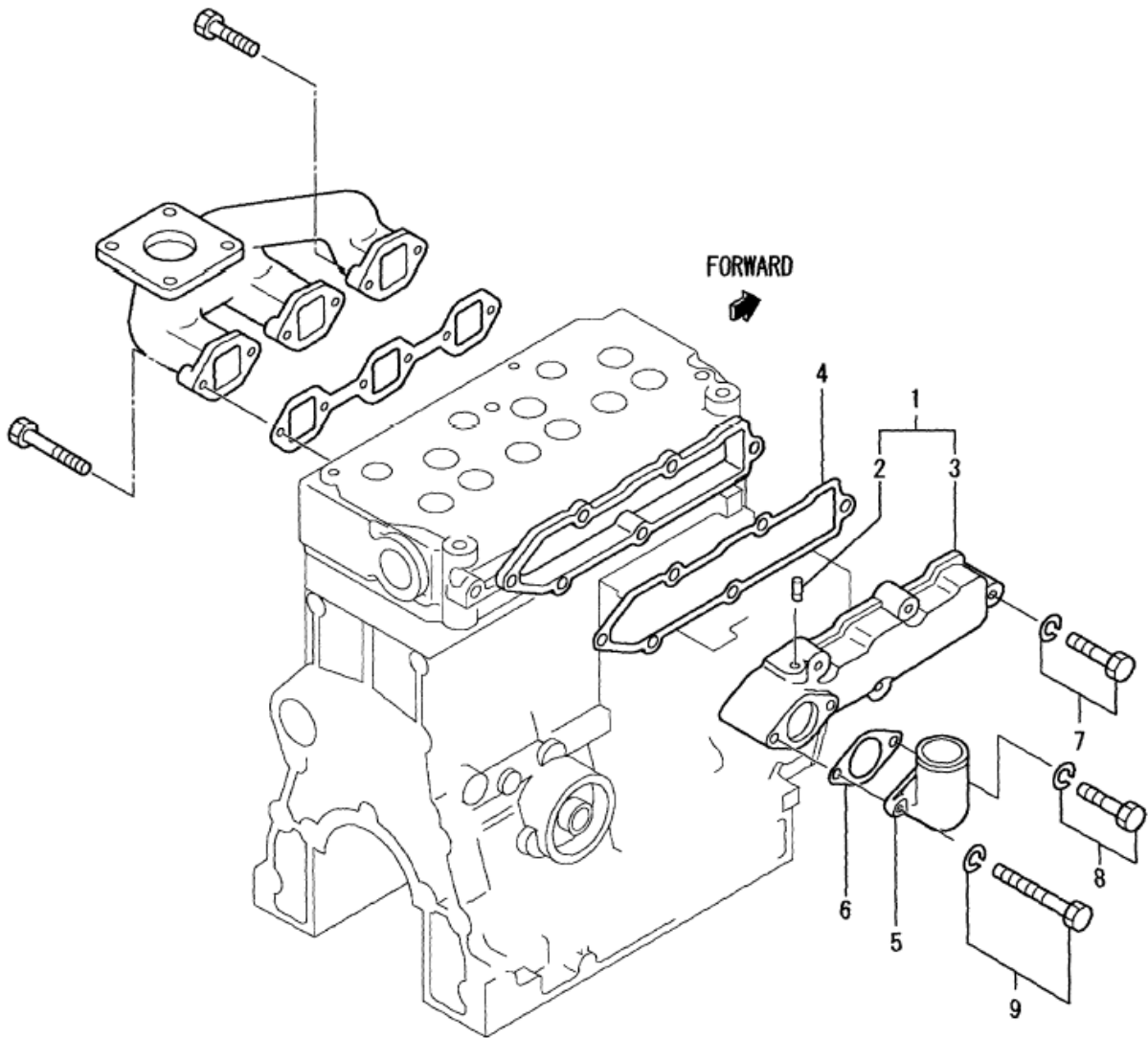
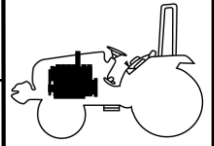

NOTE

T273:S3L2 , T233:S3L

FIG 120

EXHAUST SYSTEM

P1

Year / Month

2007 / 11

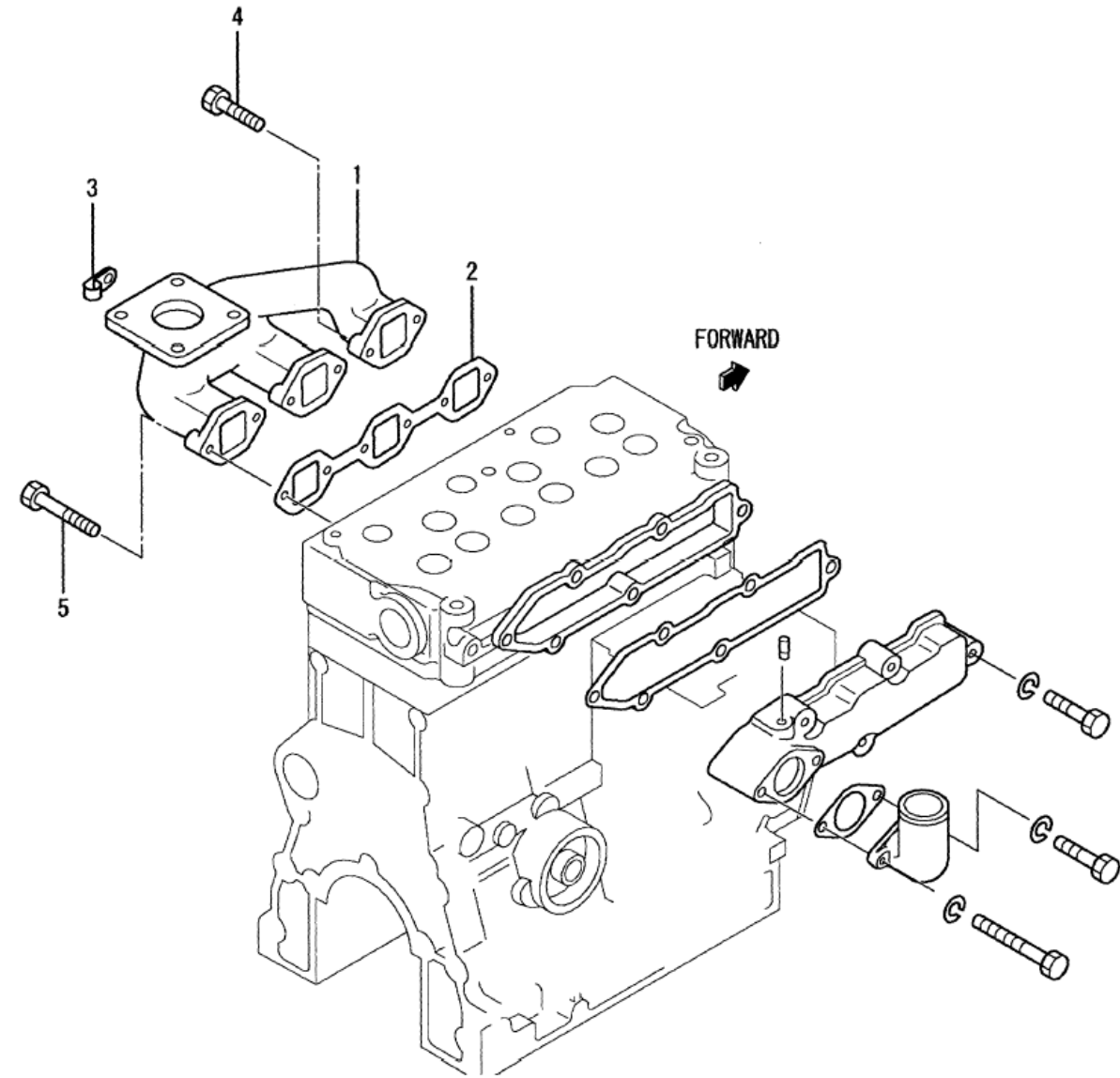
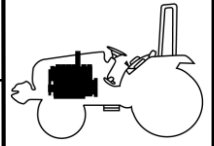

NOTE

T273:S3L2 , T233:S3L

FIG 121

T233/T273

OIL PUMP

P1

Year / Month

2007 / 11

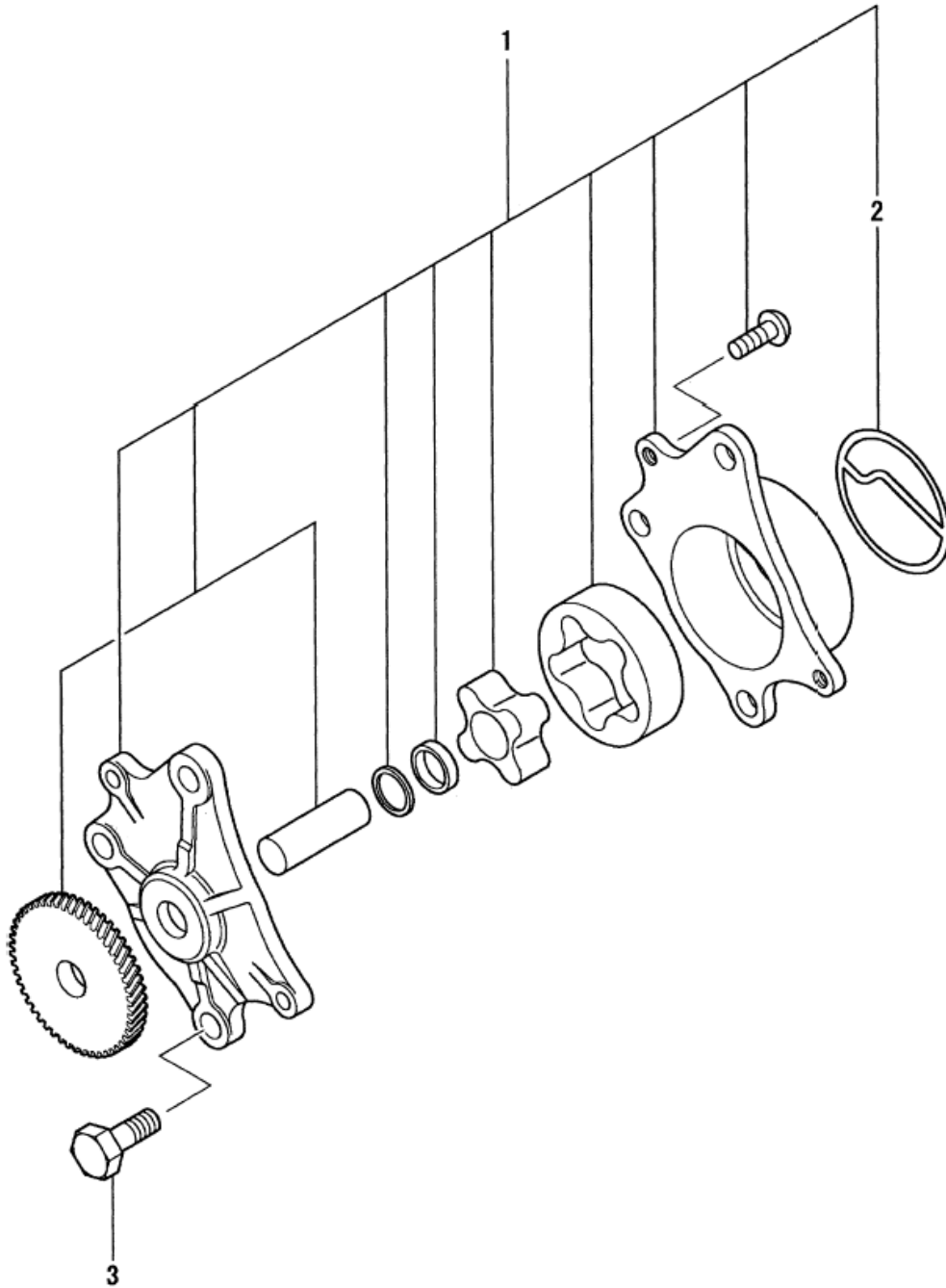
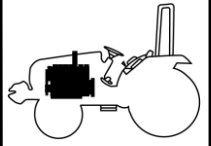

NOTE

T273:S3L2 , T233:S3L

FIG 122

T233/T273

# OIL STRAINER

P1

Year / Month

2007 / 11

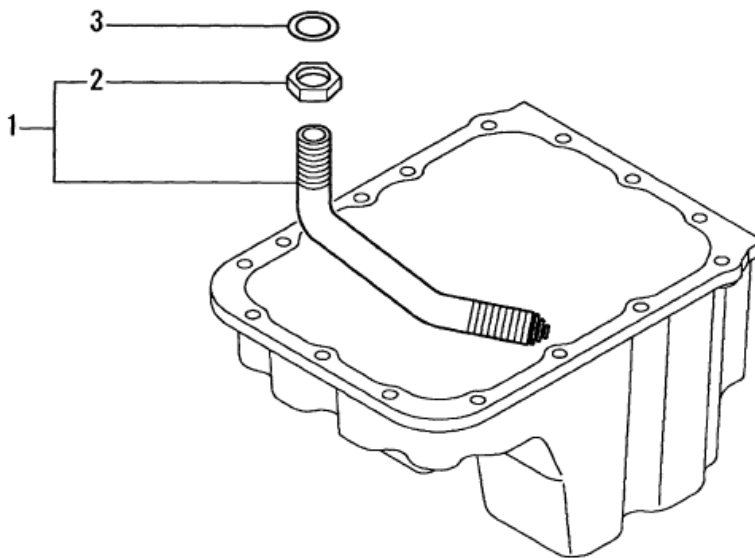
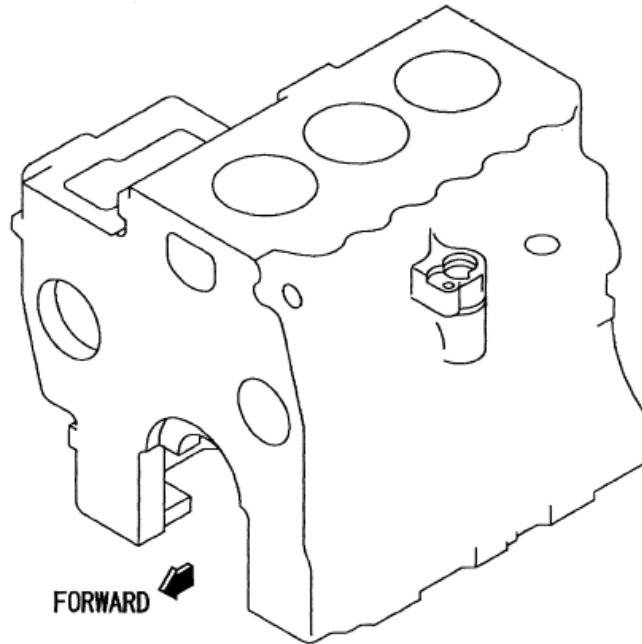
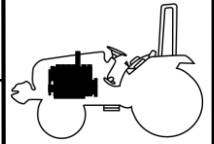

NOTE

T273:S3L2 , T233:S3L

FIG 123

T233/T273

OIL SYSTEM

P1

Year / Month

2007 / 11

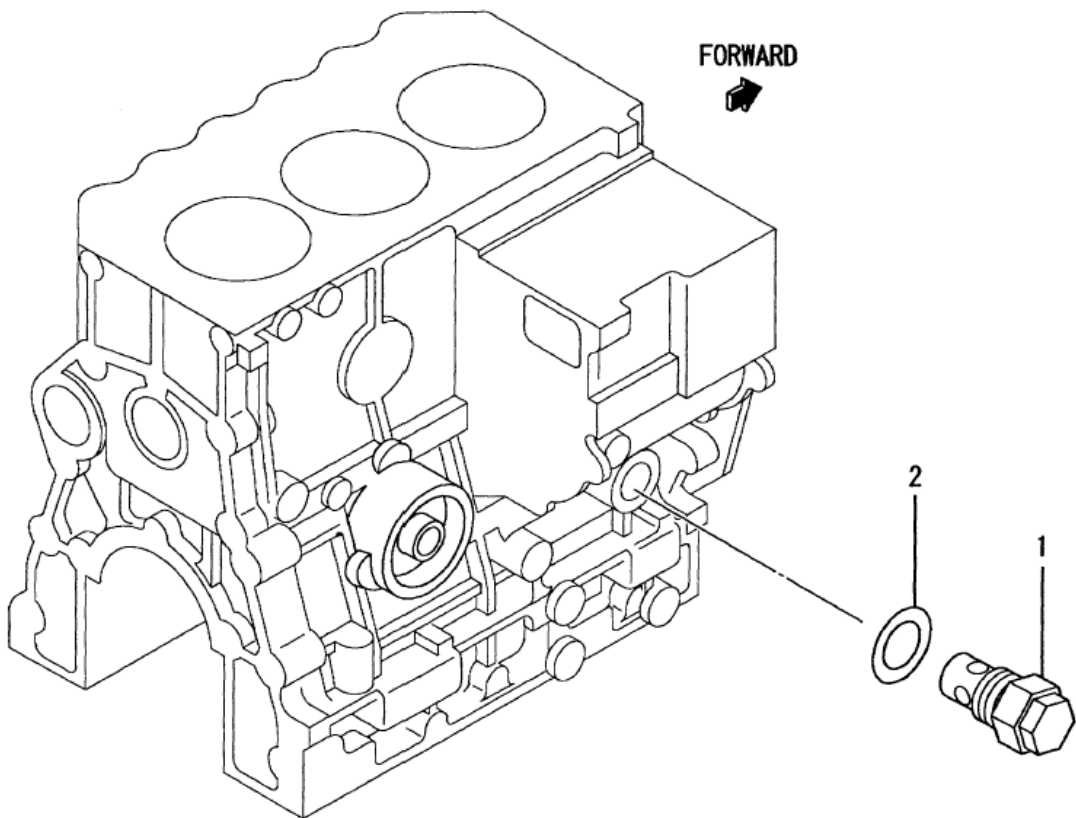
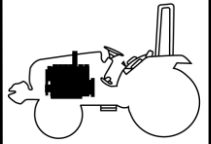

NOTE

T273:S3L2 , T233:S3L

FIG 124

OIL FILTER & GAGE

P1

Year / Month

2007 / 11

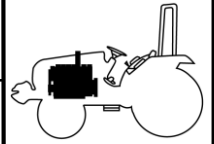

T233/T273

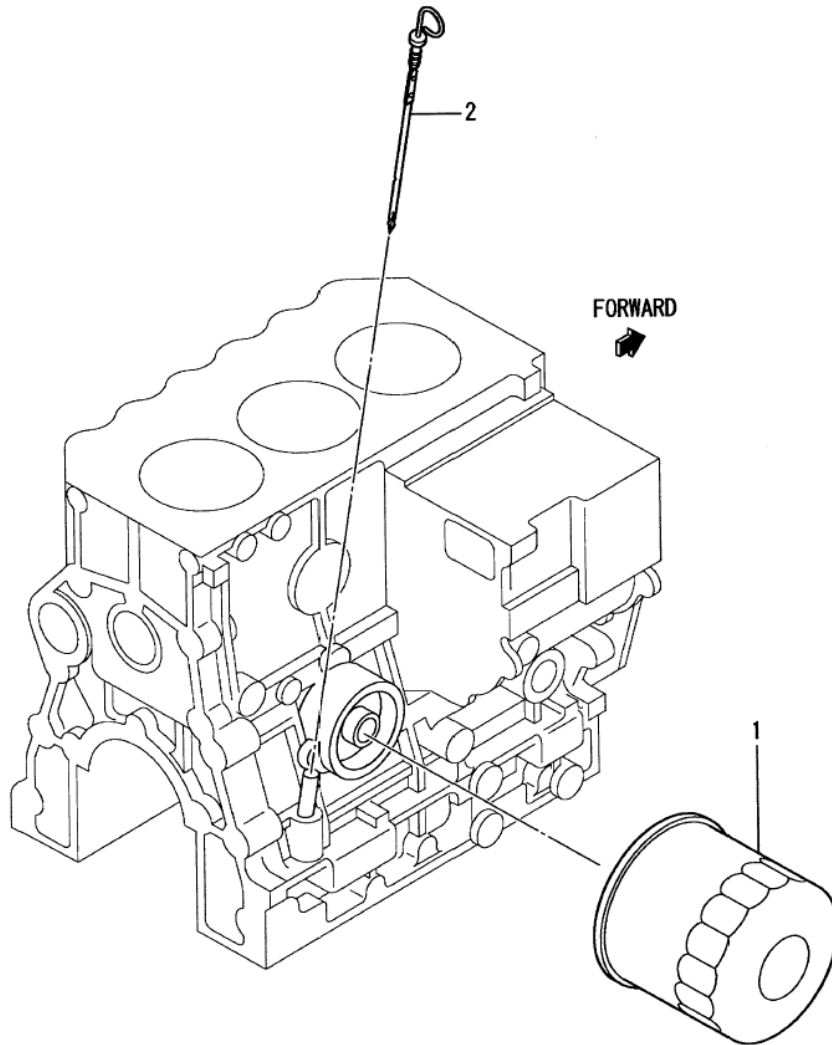

NOTE

T273:S3L2 , T233:S3L



FIG 125

BREATHER

P1

Year / Month

2007 / 11

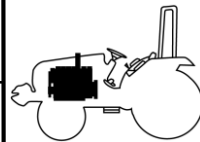

T233/T273

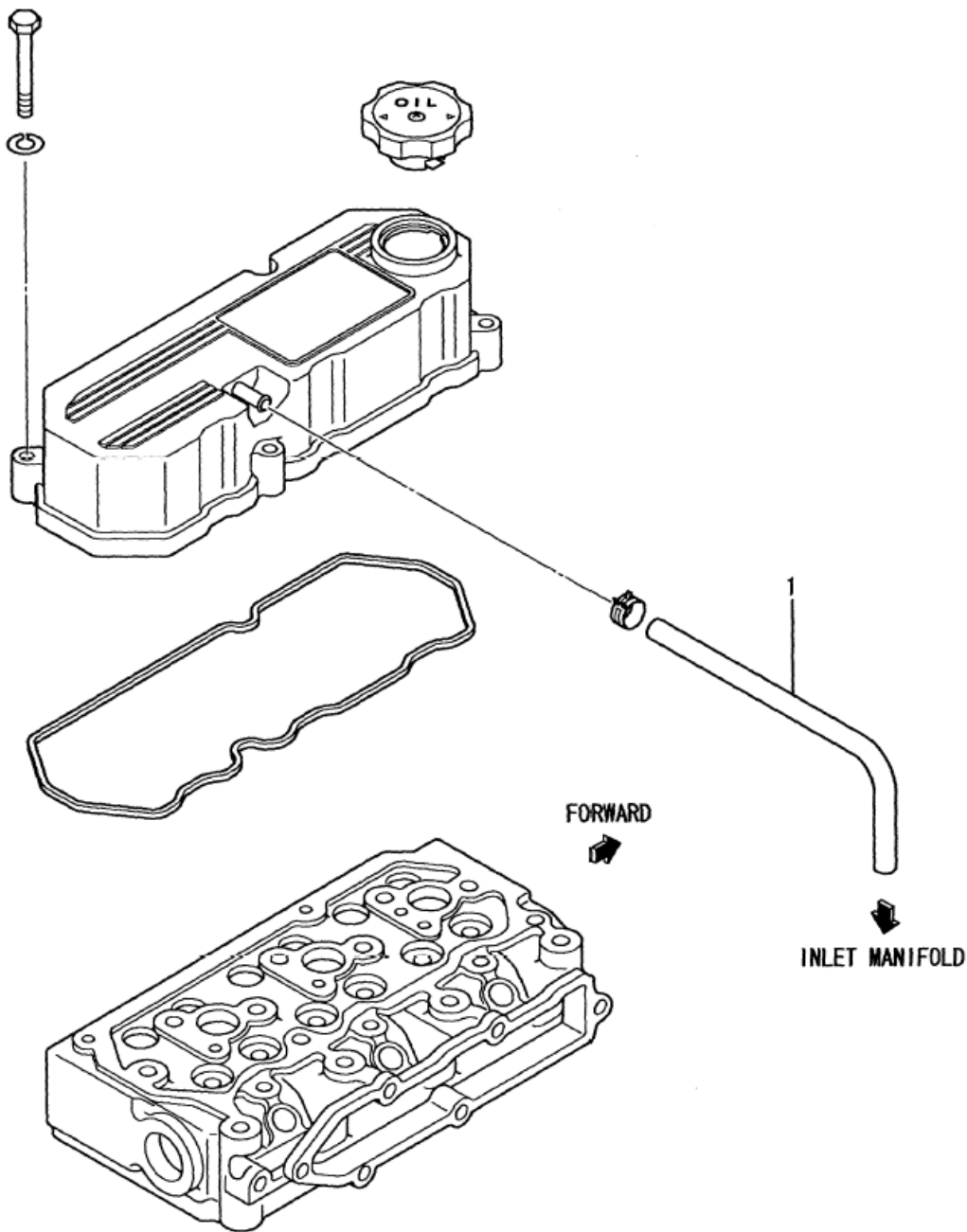

NOTE

T273:S3L2 , T233:S3L

FIG 126

T233/T273

# WATER PUMP & PULLEY

P1

Year / Month

2007 / 11

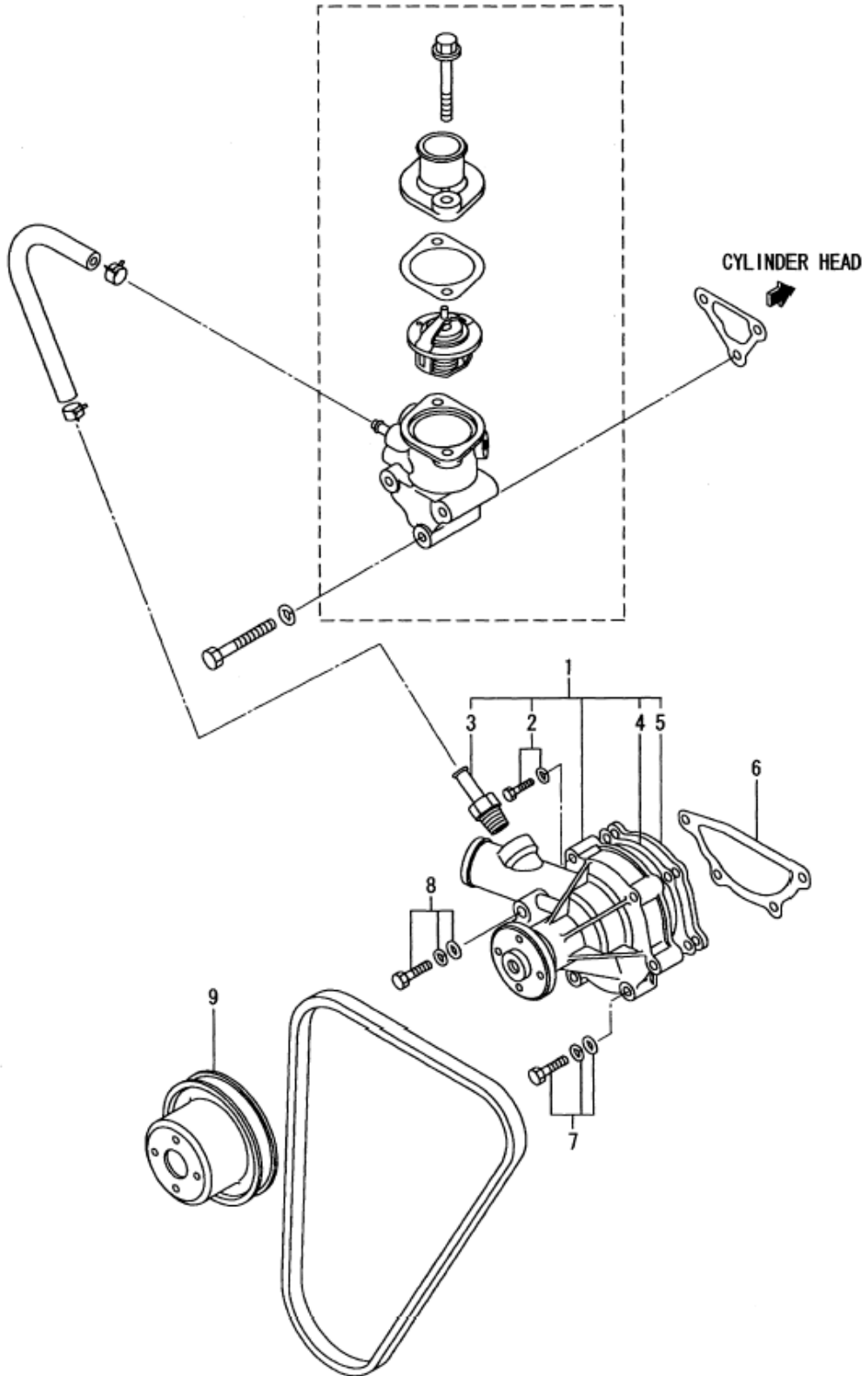
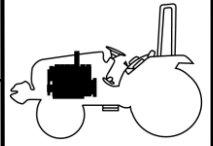

NOTE

T273:S3L2 , T233:S3L

FIG 127

COOLING SYSTEM

P1

Year / Month

2007 / 11

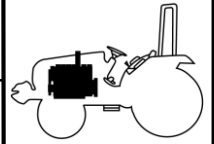

T233/T273

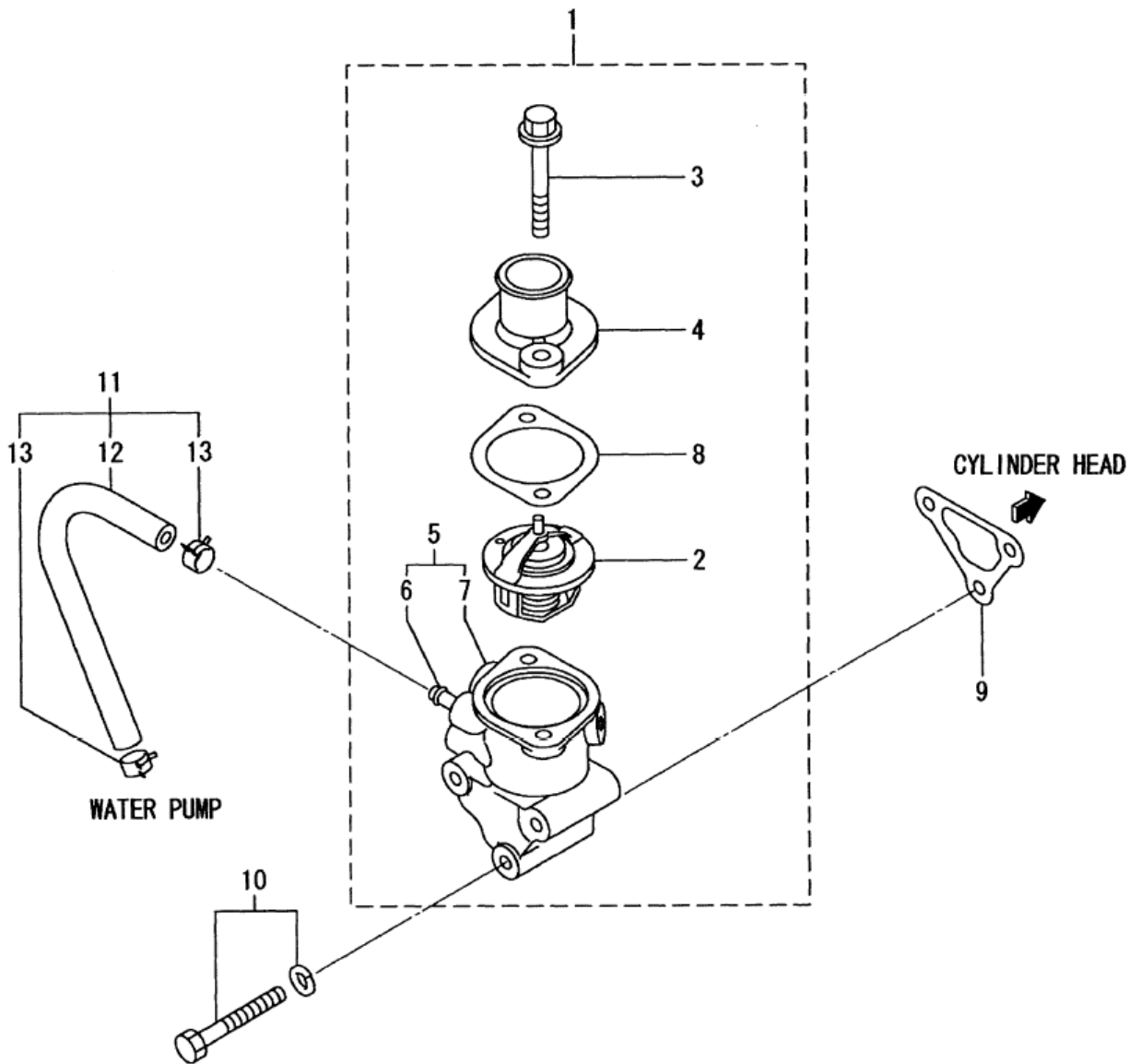

NOTE

T273:S3L2 , T233:S3L

FIG 128

T233/T273

FAN & V-BELT

P1

Year / Month

2007 / 11

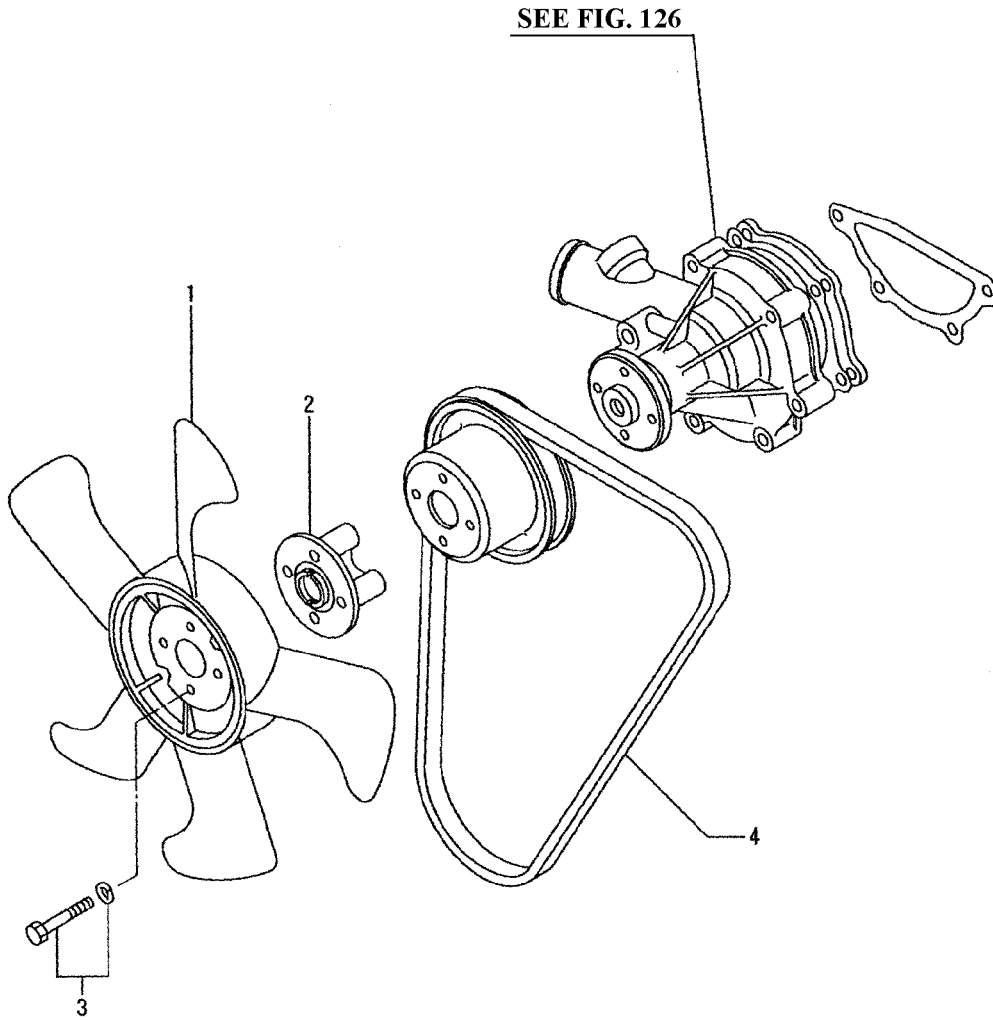
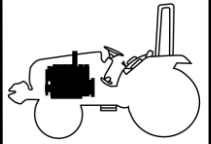

NOTE

T273:S3L2 , T233:S3L

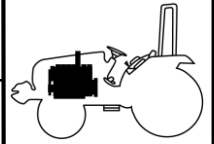

T233/T273

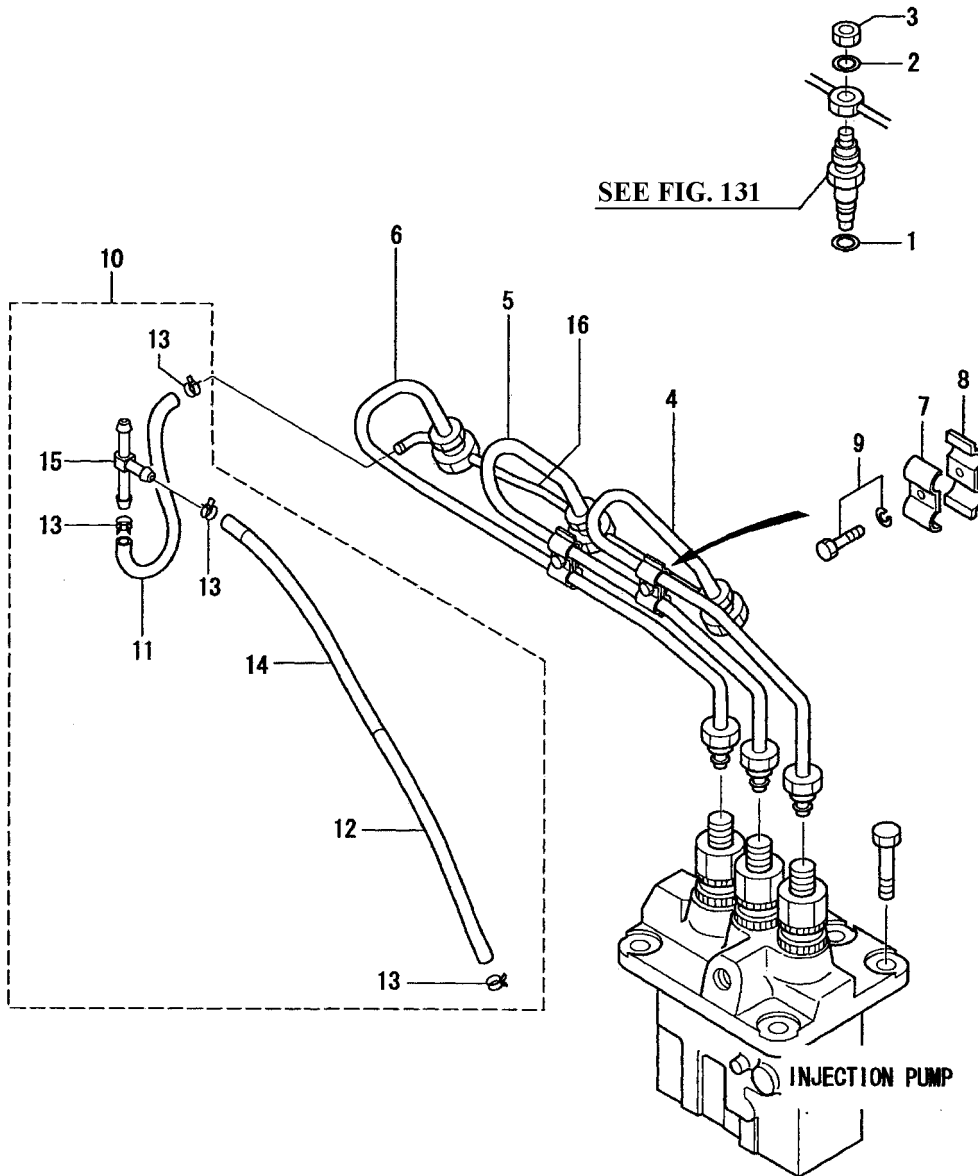

NOTE

T273:S3L2 , T233:S3L

FIG 131

T233/T273

# NOZZLE & NOZZLE HOLDER

P1

Year / Month

2007 / 11

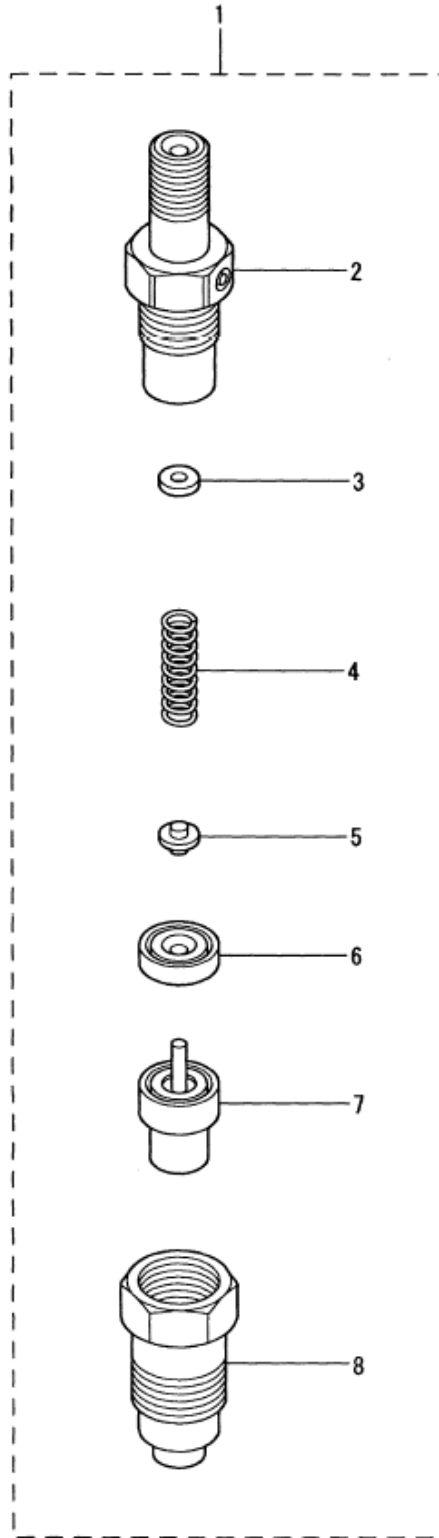
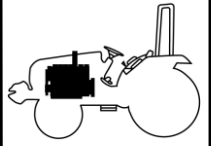

NOTE

T273:S3L2 , T233:S3L

FIG 133

GOVERNOR

P1

Year / Month

2007 / 11

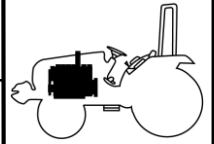

T233/T273

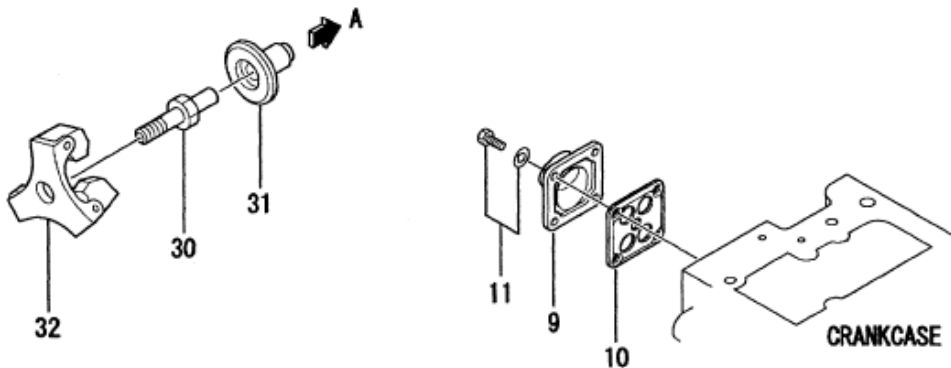
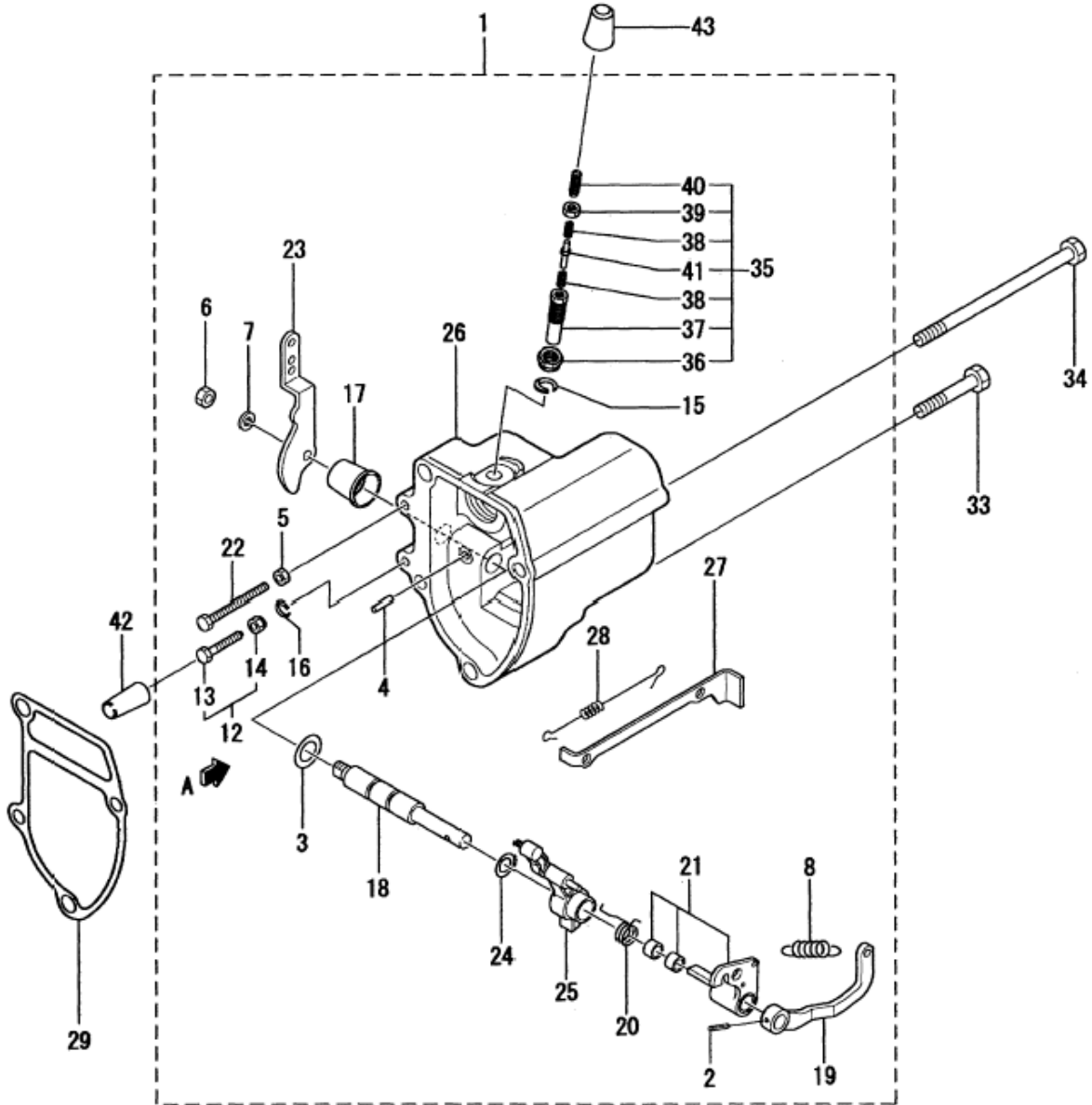

NOTE

T273:S3L2 , T233:S3L

FIG 134

T233/T273

INJECTION PUMP

P1

Year / Month

2007 / 11

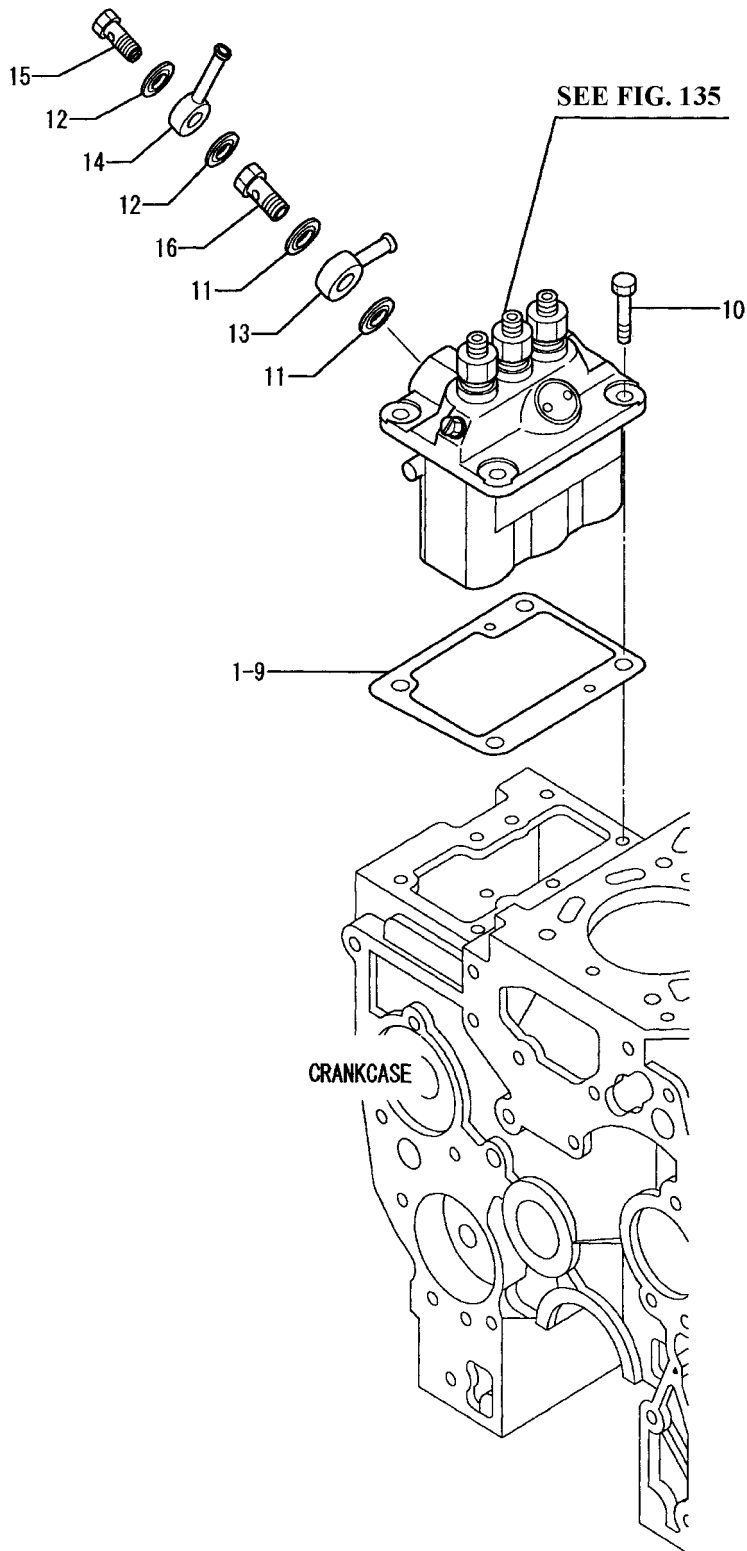
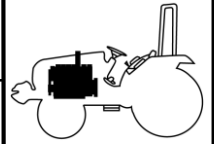

NOTE

T273:S3L2 , T233:S3L



FIG 135

INJECTION PUMP

T233/T273

P1

Year / Month

2007 / 11

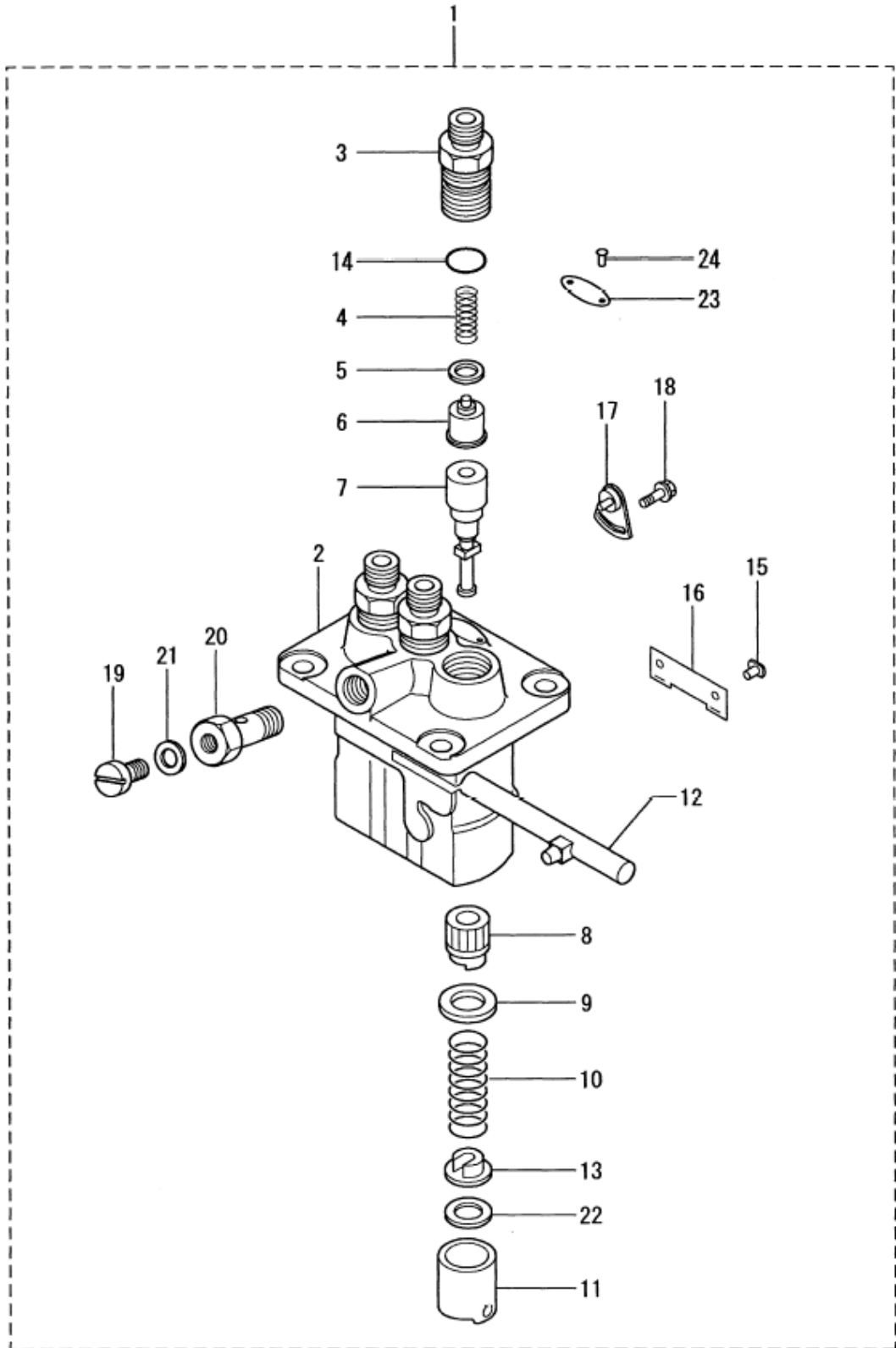
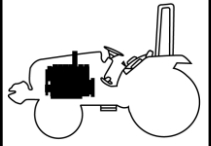

NOTE

T273:S3L2 , T233:S3L

FIG 136

FUEL INJECTION PUMP DRIVE

P1

Year / Month

2007 / 11

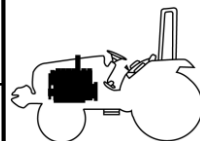

T233/T273

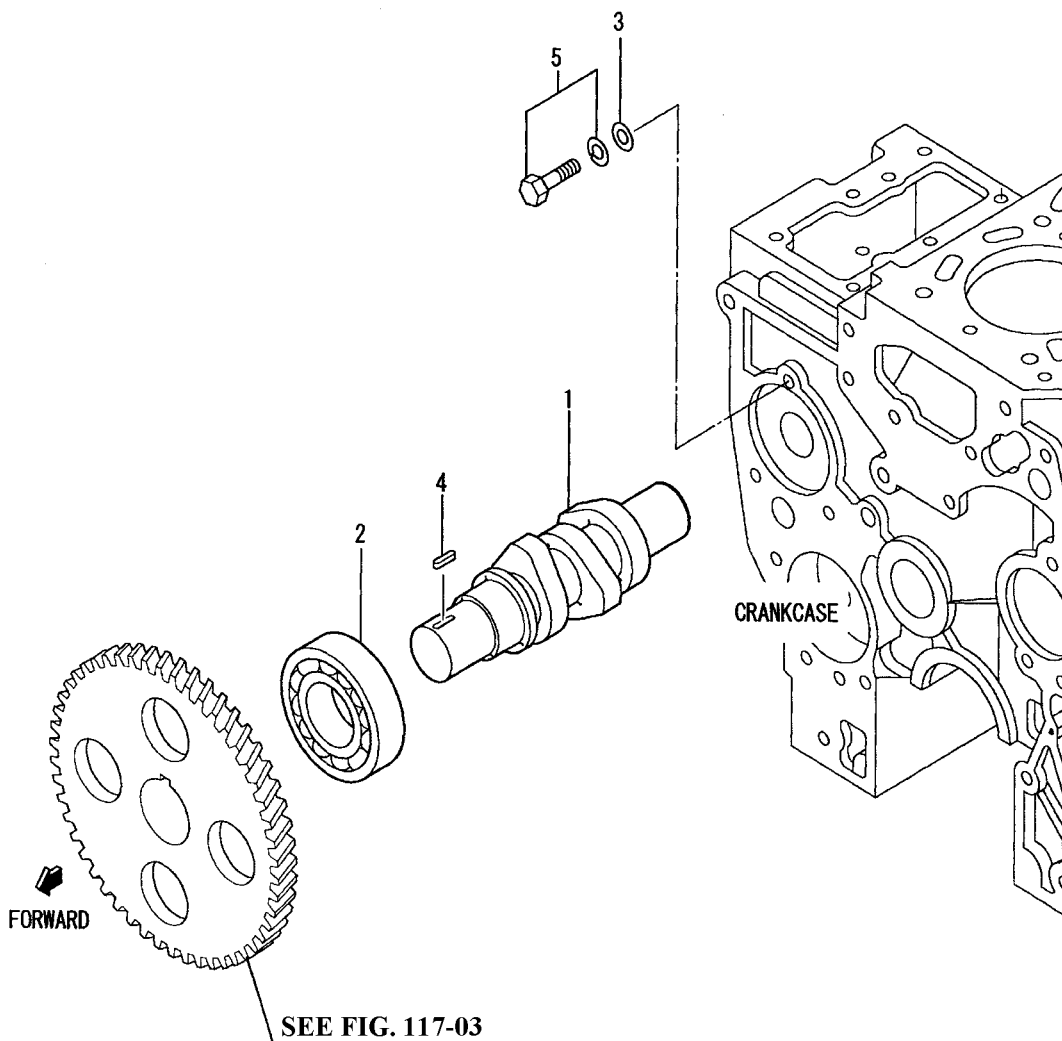

NOTE

T273:S3L2 , T233:S3L

FIG 137

T233/T273

# STARTER

P1

Year / Month

2007 / 11

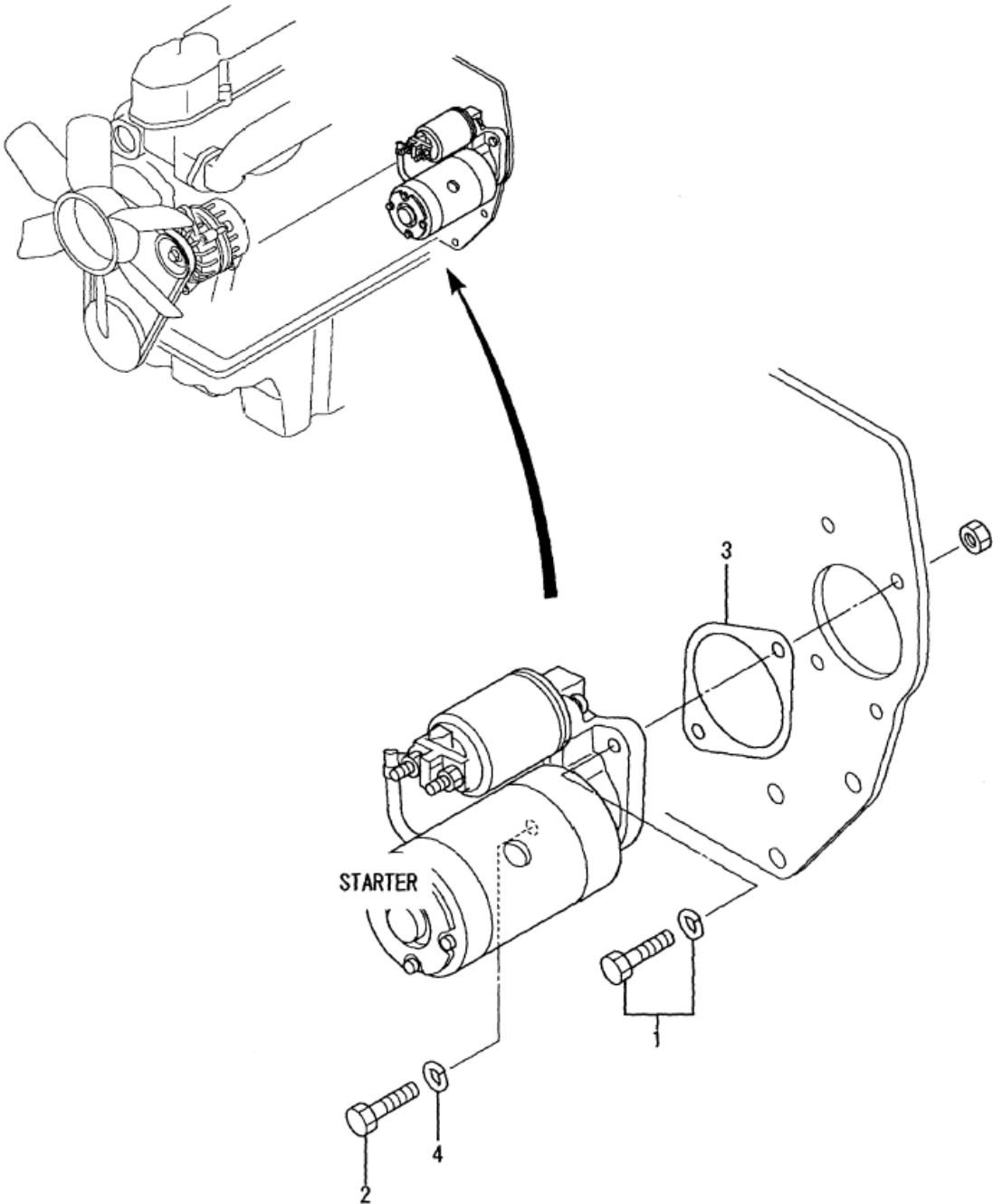
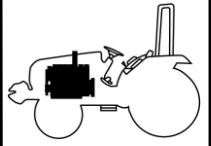

NOTE

T273:S3L2 , T233:S3L

FIG 138

STARTER(12V-1.6KW)

P1

Year / Month

2007 / 11

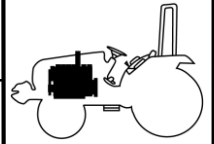

T233/T273

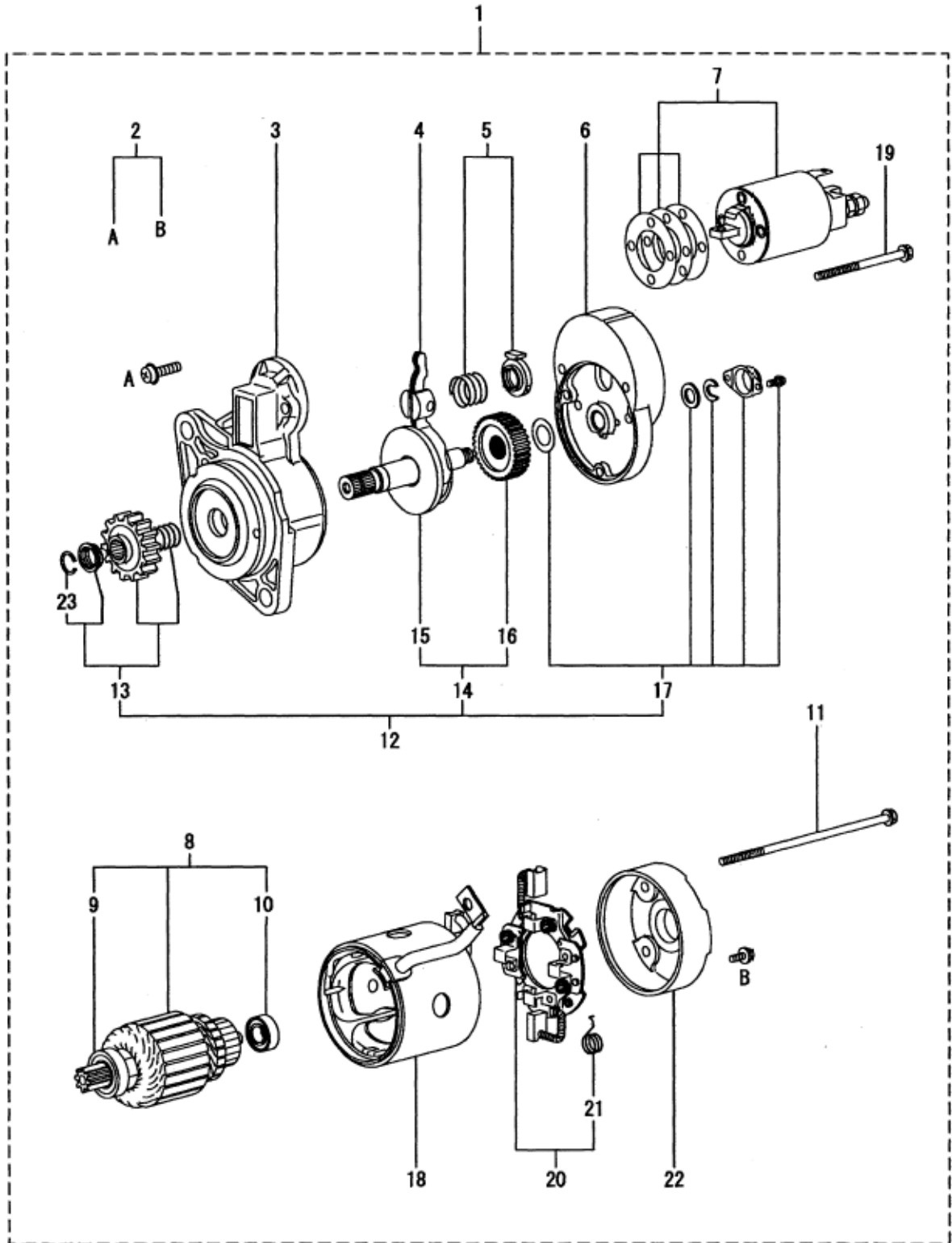

PART WITHOUT REF. NO. WON'T BE SUPPLIED

NOTE

T273:S3L2 , T233:S3L

FIG 139

GLOW PLUG

P1

Year / Month

2007 / 11

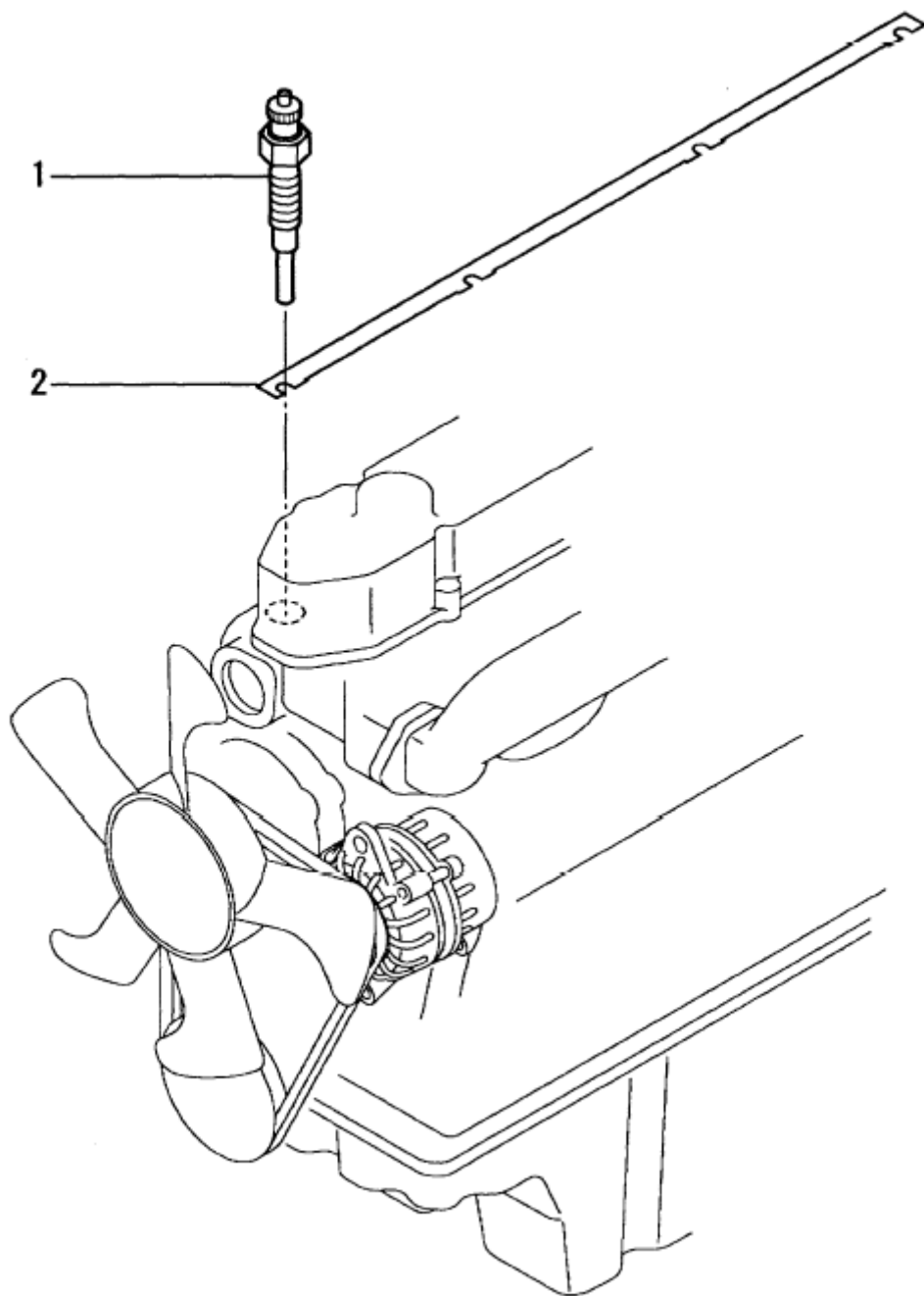
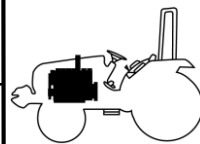

NOTE

T273:S3L2 , T233:S3L

FIG 140

T233/T273

# ALTERNATOR

P1

Year / Month

2007 / 11

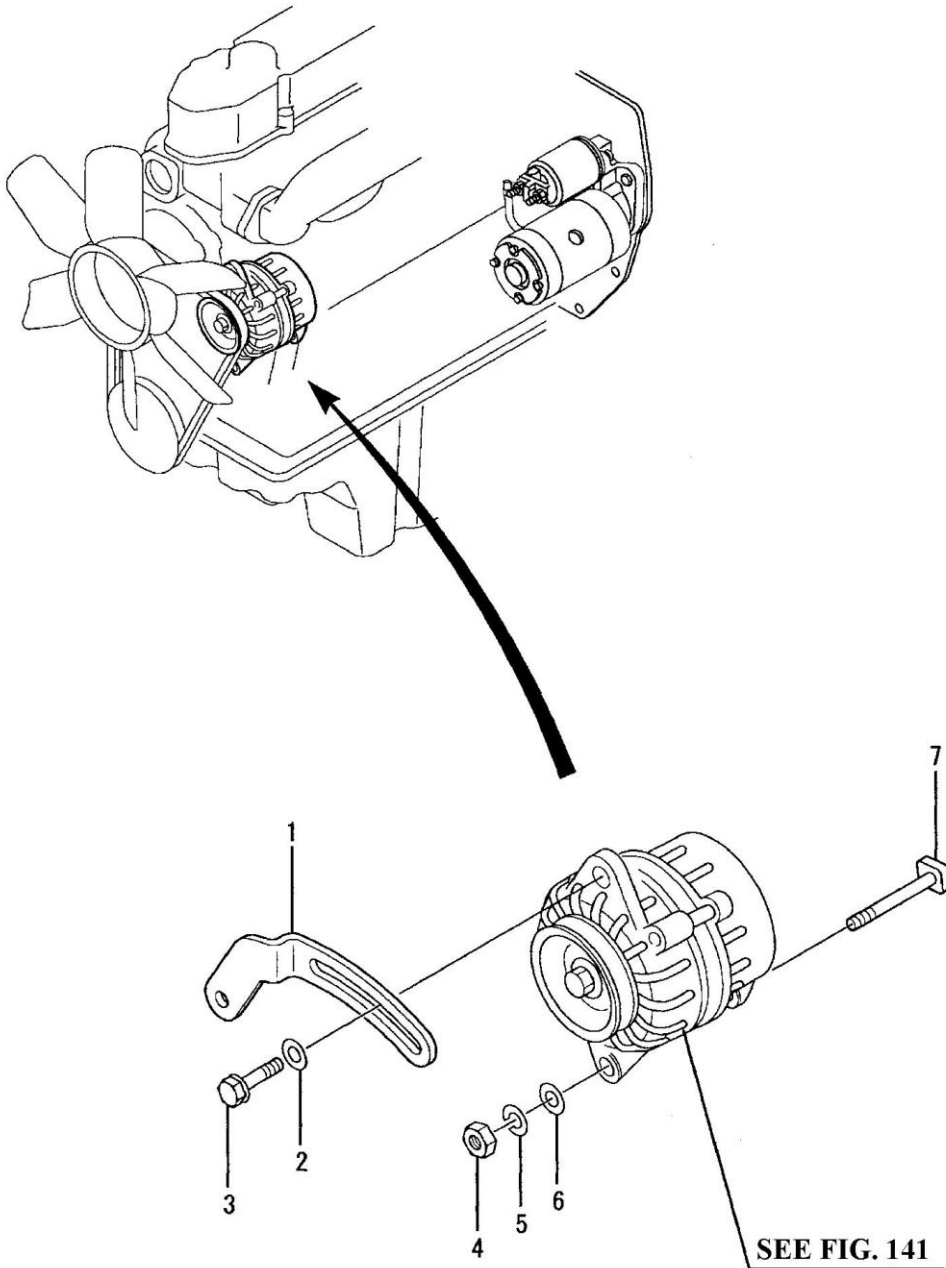
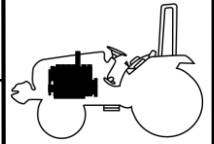

NOTE

T273:S3L2 , T233:S3L

FIG 141

ALTERNATOR(12V-50A)

T233/T273

P1

Year / Month

2007 / 11

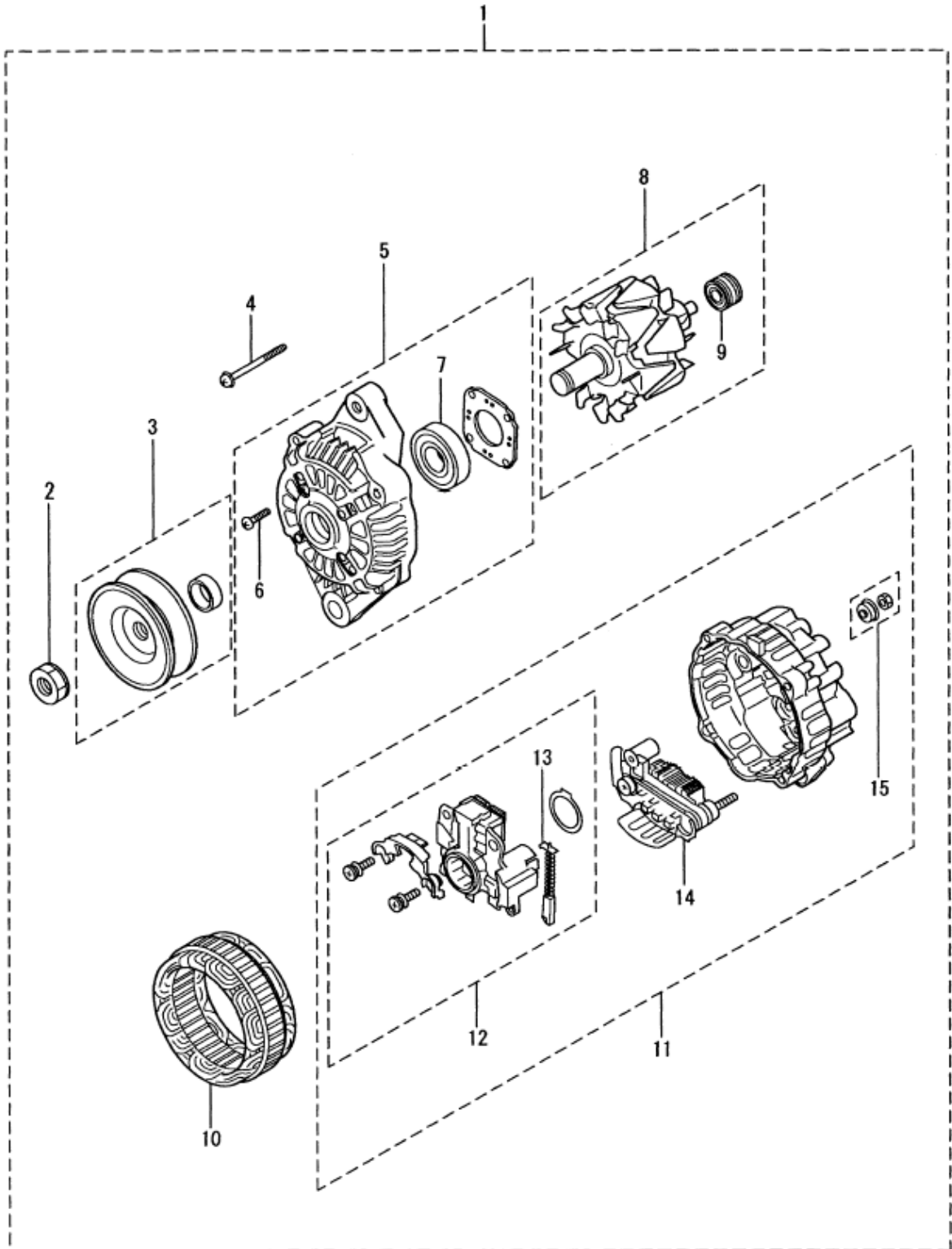
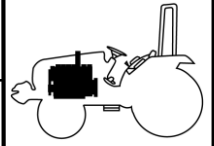

PART WITHOUT REF. NO. WON'T BE SUPPLIED

NOTE

T273:S3L2 , T233:S3L

FIG 142

T233/T273

ENGINE CONTROL

P1

Year / Month

2007 / 11

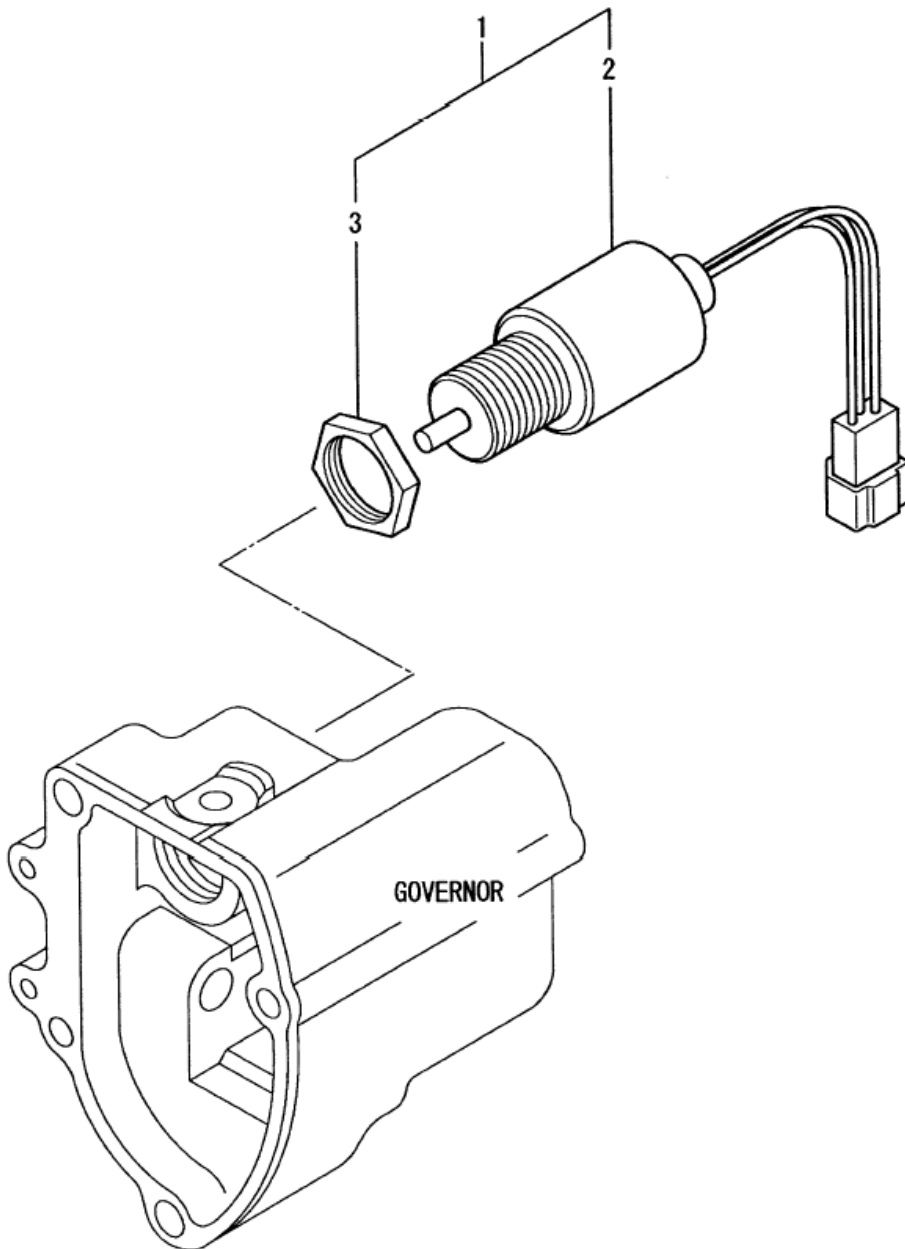
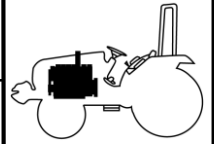

NOTE

T273:S3L2 , T233:S3L



FIG 143

T233/T273

INSTRUMENT

P1

Year / Month

2007 / 11

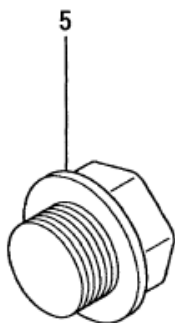
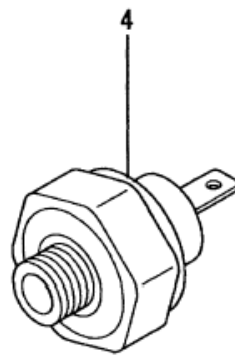
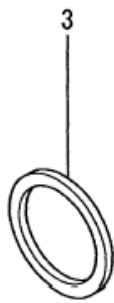
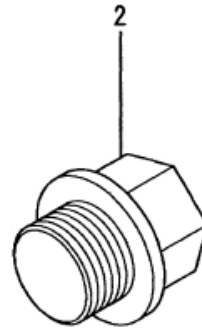
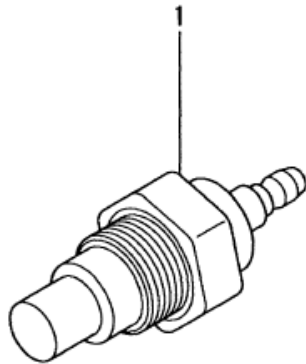
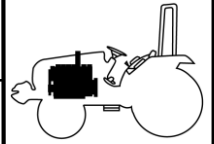

NOTE

T273:S3L2 , T233:S3L

FIG 144

T233/T273

ACCESSORY

P1

Year / Month

2007 / 11

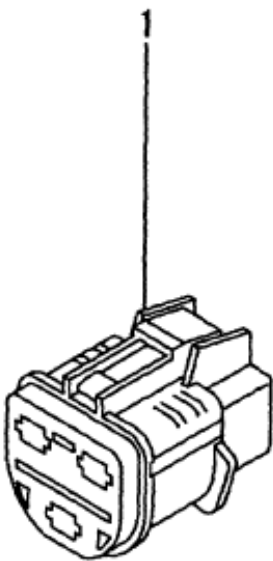
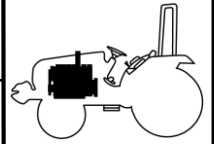

NOTE

T273:S3L2 , T233:S3L

# FIG 145

# OVERHAUL GASKET KIT

T233/T273

P1

Year / Month

2007 / 11

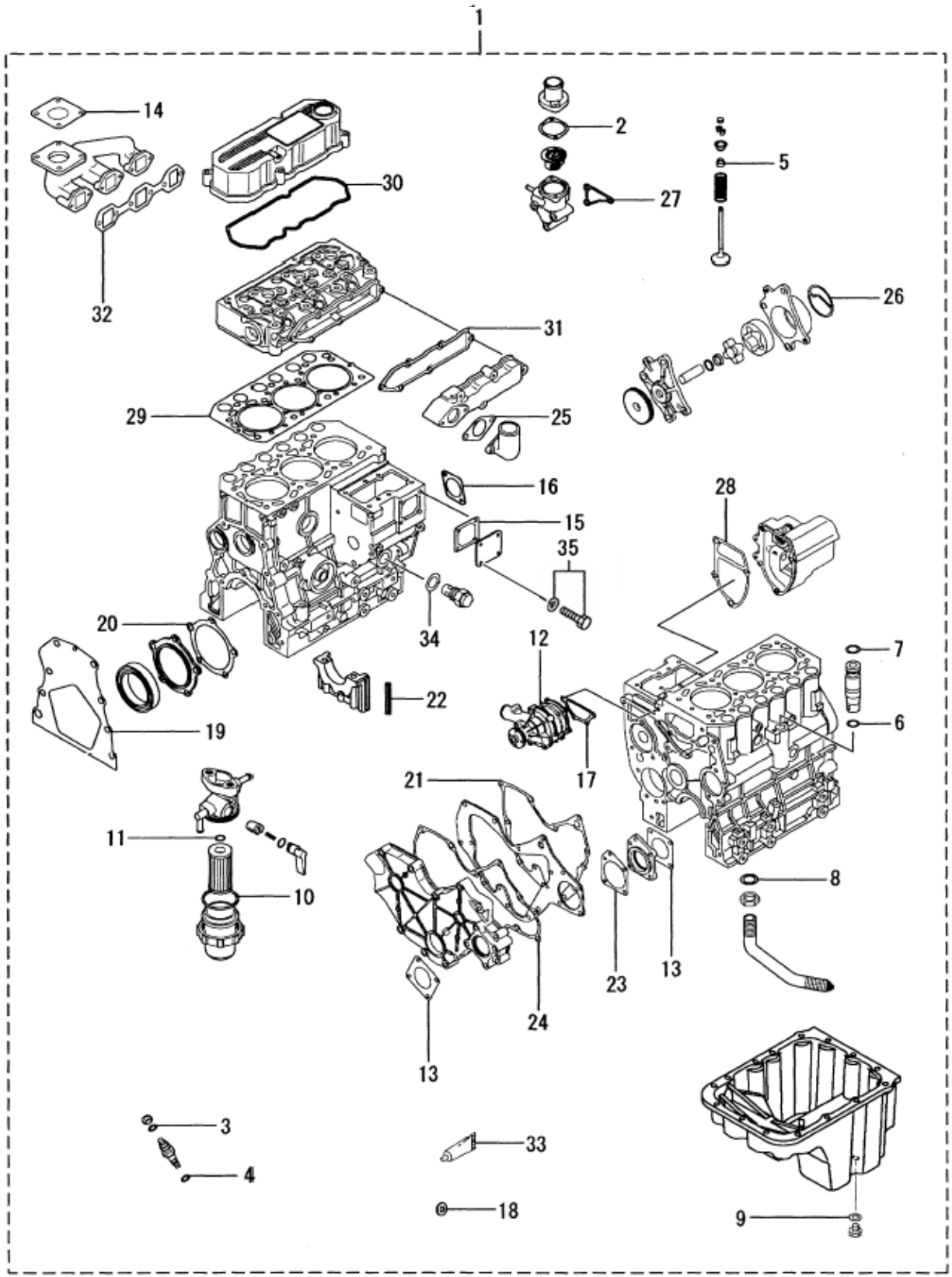
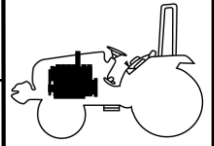

## NOTE

T273:S3L2 , T233:S3L